

# CHAPTER 2

## Introduction of the left hand

The first exercise to use both left and right hand together gradually introduces one finger at the time.

As a finger pattern throughout this exercise I have chosen:

**0 - Tone - 1 - Tone - 2 - Semi tone - 3 - Tone - 4.**

This results in the second and third finger being placed against each other. All other fingers are separated. As a reminder I have added the / \ symbol to indicate where the semi tone is.

Important goals for this exercise are:

- Keep your fingers always round.
- Learn to play in tune by using either an electronic tuner or by playing along with the recording until your intonation matches that of the recording.
- When placing or removing a finger, move only the finger and not the hand nor wrist. Make sure your left wrist stays straight and your thumbs remain relaxed.
- It is important to keep as many fingers down as possible.
- Stay together with the metronome as the rhythm speeds up, and keep your bow straight at all times.

### 1st Finger Pattern

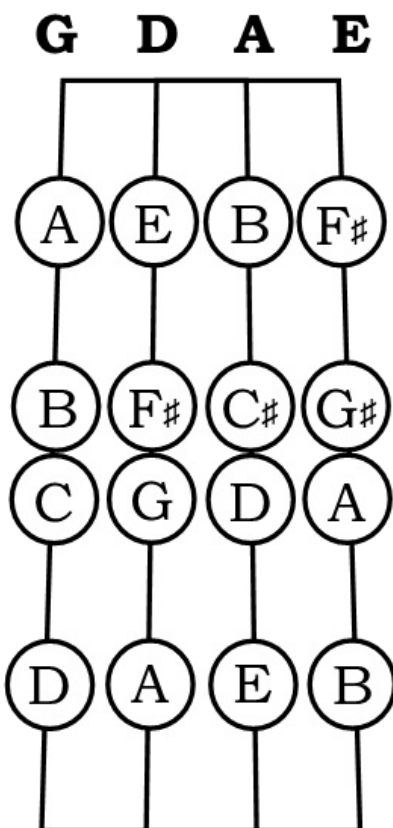

**A**

0                    1                    0                    1                    0

0 1 0 1 0

D E D E etc.  
Re Mi Re Mi

0 1 0 1 0

A B A B etc.  
La Si La Si

0 1 0 1 0

E F# E F# etc.  
Mi Fa# Mi Fa#





E Mi F# Fa# G# Sol# F# Fa# G# Sol#



G Sol A La B Si C Do B Si C Do



D Re E Mi F# Fa# G Sol F# Fa# G Sol



0 1 2 3 2 3

A B C# D C# D  
La Si Do# Re Do# Re

Musical staff 4: Treble clef, 8 measures of whole notes. Fingerings are indicated above the notes: 0, 1, 2, 3, 2, 3. Solfège labels are written below the notes: A, B, C#, D, C#, D. The corresponding solfège syllables are: La, Si, Do#, Re, Do#, Re.

0 1 2 3 2 3

E F# G# A G# A  
Mi Fa# Sol# La Sol# La

Musical staff 8: Treble clef, 8 measures of whole notes. Fingerings are indicated above the notes: 0, 1, 2, 3, 2, 3. Solfège labels are written below the notes: E, F#, G#, A, G#, A. The corresponding solfège syllables are: Mi, Fa#, Sol#, La, Sol#, La.

D

0 1 2 3 4 3 4

G A B C D C D  
Sol La Si Do Re Do Re

0 1 2 3 4 3 4

D E F# G A G A  
Re Mi Fa# Sol La Sol La

0 1 2 3 4 3 4

A B C# D E D E  
La Si Do# Re Mi Re Mi

Detailed description: This block shows the first line of a musical score. It consists of a single treble clef staff with a key signature of one sharp (F#). The notes are A, B, C#, D, E, D, E. Above the staff, fingerings are indicated: 0 for A, 1 for B, 2 for C#, 3 for D, 4 for E, 3 for D, and 4 for E. A slur is placed over the notes C#, D, and E. Below the staff, the notes are labeled with their solfège names: La, Si, Do#, Re, Mi, Re, Mi.

Detailed description: This block shows the second line of the musical score. It consists of a single treble clef staff with a key signature of one sharp (F#). The notes are B, C#, D, E, D, C#, B. A slur is placed over the notes B, C#, and D. The notes are labeled with their solfège names: Si, Do#, Re, Mi, Re, Do#, Si.

Detailed description: This block shows the third line of the musical score. It consists of a single treble clef staff with a key signature of one sharp (F#). The notes are B, C#, D, E, D, C#, B. The notes are labeled with their solfège names: Si, Do#, Re, Mi, Re, Do#, Si.

Detailed description: This block shows the fourth line of the musical score. It consists of a single treble clef staff with a key signature of one sharp (F#). The notes are B, C#, D, E, D, C#, B. The notes are labeled with their solfège names: Si, Do#, Re, Mi, Re, Do#, Si.

Detailed description: This block shows the fifth line of the musical score. It consists of a single treble clef staff with a key signature of one sharp (F#). The notes are B, C#, D, E, D, C#, B. The notes are labeled with their solfège names: Si, Do#, Re, Mi, Re, Do#, Si.

0 1 2 3 4 3 4

E F# G# A B A B  
Mi Fa# Sol# La Si La Si

Detailed description: This block shows the sixth line of a musical score. It consists of a single treble clef staff with a key signature of two sharps (F# and C#). The notes are E, F#, G#, A, B, A, B. Above the staff, fingerings are indicated: 0 for E, 1 for F#, 2 for G#, 3 for A, 4 for B, 3 for A, and 4 for B. A slur is placed over the notes F#, G#, and A. Below the staff, the notes are labeled with their solfège names: Mi, Fa#, Sol#, La, Si, La, Si.

Detailed description: This block shows the seventh line of the musical score. It consists of a single treble clef staff with a key signature of two sharps (F# and C#). The notes are F#, G#, A, B, A, G#, F#. A slur is placed over the notes F#, G#, and A. The notes are labeled with their solfège names: Fa#, Sol#, La, Si, La, Sol#, Fa#.

Detailed description: This block shows the eighth line of the musical score. It consists of a single treble clef staff with a key signature of two sharps (F# and C#). The notes are F#, G#, A, B, A, G#, F#. The notes are labeled with their solfège names: Fa#, Sol#, La, Si, La, Sol#, Fa#.

Detailed description: This block shows the ninth line of the musical score. It consists of a single treble clef staff with a key signature of two sharps (F# and C#). The notes are F#, G#, A, B, A, G#, F#. The notes are labeled with their solfège names: Fa#, Sol#, La, Si, La, Sol#, Fa#.

Detailed description: This block shows the tenth line of the musical score. It consists of a single treble clef staff with a key signature of two sharps (F# and C#). The notes are F#, G#, A, B, A, G#, F#. The notes are labeled with their solfège names: Fa#, Sol#, La, Si, La, Sol#, Fa#.

This exercise is ideal to practice the curving of the fingers of the left hand. Once you've placed a finger, keep it down as long as possible. With the right curve, the open strings will sound clear without lifting any fingers before the music requires.

Parts E, F and G use the exact same notes, but become increasingly difficult. Be patient and challenge yourself to always have a nice quality of sound on the open strings without removing any fingers from the lower string.

**E**

0 0 1 0 2 0

G D A D B D  
Sol Re La Re Si Re  
3 0 4 0 3 0

C D D D C D  
Do Re Re Re Do Re  
2 0 1 0 0

B D A D G  
Si Re La Re Sol  
0 0 1 0 2 0

D A E A F# A  
Re La Mi La Fa# La  
3 0 4 0 3 0

G A A A G A  
Sol La La La Sol La  
2 0 1 0 0

F# A E A D  
Fa# La Mi La Re  
0 0 1 0 2 0

A E B E C# E  
La Mi Si Mi Do# Mi  
3 0 4 0 3 0

D E E E D E  
Re Mi Mi Mi Re Mi  
2 0 1 0 0

C# E B E A  
Do# Mi Si Mi La



F

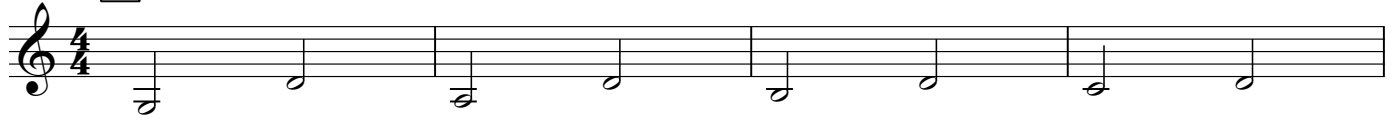

G







Musical staff 3: Treble clef, whole notes with fingerings 0, 1, 2, 1, 2 and solfège labels La, Si, Do, Si, Do.



Musical staff 7: Treble clef, whole notes with fingerings 0, 1, 2, 1, 2 and solfège labels Mi, Fa#, Sol, Fa#, Sol.



0 1 2 3 2 3

G A B $\flat$  C B $\flat$  C  
Sol La Sib Do Sib Do

0 1 2 3 2 3

D E F G F G  
Re Mi Fa Sol Fa Sol

0 1 2 3 2 3

A B C D C D  
La Si Do Re Do Re

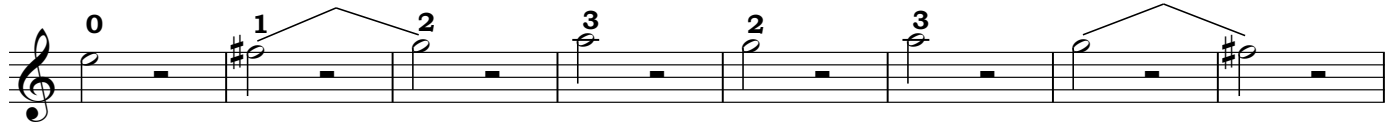

E            F#            G            A            G            A  
Mi            Fa            Sol            La            Sol            La



J 0 1 2 3 4 3 4

G Sol A La Bb Sib C Do D Re C Do D Re

0 1 2 3 4 3 4

D Re E Mi F Fa G Sol A La G Sol A La

0 1 2 3 4 3 4

A B C D E D E  
La Si Do Re Mi Re Mi

Detailed description: This block shows the first line of a musical exercise. It consists of a single treble clef staff with a key signature of one sharp (F#). The notes are A, B, C, D, E, D, E. Fingerings are indicated above the notes: 0 for A, 1 for B, 2 for C, 3 for D, 4 for E, 3 for D, and 4 for E. A slur is placed over the B, C, and D notes. Below the staff, the notes are labeled with their letter names and solfège syllables: A (La), B (Si), C (Do), D (Re), E (Mi), D (Re), E (Mi).

Detailed description: This block shows the second line of the musical exercise. It consists of a single treble clef staff with a key signature of one sharp (F#). The notes are A, B, C, D, E, D, E. A slur is placed over the B, C, and D notes. This line continues the melodic line from the first line.

Detailed description: This block shows the third line of the musical exercise. It consists of a single treble clef staff with a key signature of one sharp (F#). The notes are A, B, C, D, E, D, E. This line continues the melodic line from the previous lines.

Detailed description: This block shows the fourth line of the musical exercise. It consists of a single treble clef staff with a key signature of one sharp (F#). The notes are A, B, C, D, E, D, E. This line continues the melodic line from the previous lines.

Detailed description: This block shows the fifth line of the musical exercise. It consists of a single treble clef staff with a key signature of one sharp (F#). The notes are A, B, C, D, E, D, E. This line continues the melodic line from the previous lines.

0 1 2 3 4 3 4

E F# G A B A B  
Mi Fa# Sol La Si La Si

Detailed description: This block shows the sixth line of the musical exercise. It consists of a single treble clef staff with a key signature of two sharps (F# and C#). The notes are E, F#, G, A, B, A, B. Fingerings are indicated above the notes: 0 for E, 1 for F#, 2 for G, 3 for A, 4 for B, 3 for A, and 4 for B. A slur is placed over the F#, G, and A notes. Below the staff, the notes are labeled with their letter names and solfège syllables: E (Mi), F# (Fa#), G (Sol), A (La), B (Si), A (La), B (Si).

Detailed description: This block shows the seventh line of the musical exercise. It consists of a single treble clef staff with a key signature of two sharps (F# and C#). The notes are E, F#, G, A, B, A, B. A slur is placed over the F#, G, and A notes. This line continues the melodic line from the sixth line.

Detailed description: This block shows the eighth line of the musical exercise. It consists of a single treble clef staff with a key signature of two sharps (F# and C#). The notes are E, F#, G, A, B, A, B. This line continues the melodic line from the previous lines.

Detailed description: This block shows the ninth line of the musical exercise. It consists of a single treble clef staff with a key signature of two sharps (F# and C#). The notes are E, F#, G, A, B, A, B. This line continues the melodic line from the previous lines.

Detailed description: This block shows the tenth line of the musical exercise. It consists of a single treble clef staff with a key signature of two sharps (F# and C#). The notes are E, F#, G, A, B, A, B. This line continues the melodic line from the previous lines.

**K** 0 0 1 0 2

G Sol D Re A La D Re B $\flat$  Sib

0 3 0 4 0 3

D Re C Do D Re D Re D Re C Do

0 2 0 1 0 0

D Re B $\flat$  Sib D Re A La D Re G Sol

0 0 1 0 2 0

D Re A La E Mi A La F Fa A La

3 0 4 0 3 0

G Sol A La A La A La G Sol A La

2 0 1 0 0

F Fa A La E Mi A La D Re

0 0 1 0 2 0

A La E Mi B Si E Mi C Do E Mi

3 0 4 0 3 0

D Re E Mi E Mi E Mi D Re E Mi

2 0 1 0 0

C Do E Mi B Si E Mi A La





The Third finger pattern has the semi tone between the third and fourth finger:

**0 - Tone - 1 - Tone - 2 - Tone- 3 - Semi tone - 4**

The finger pattern 0, 1 and 0, 1, 2 are identical to exercises 1 and 2. There is no need to repeat those, so we start straight away with the exercises that differ from the previous ones.

### 3rd Finger Pattern

**G D A E**

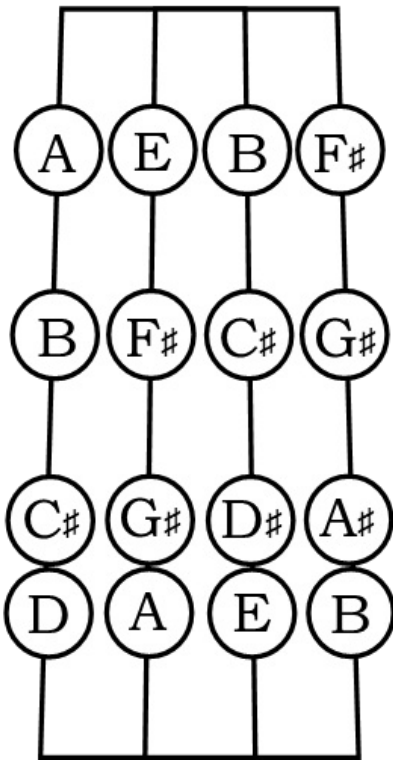

**N**  
0                    1                    2                    3                    2

G                    A                    B                    C#                    B  
Sol                    La                    Si                    Do#                    Si

3  
C#                    Do

0                    1                    2                    3                    2                    3

D                    E                    F#                    G#                    F#                    G#  
Re                    Mi                    Fa#                    Sol#                    Fa#                    Sol#



0 1 2 3 2 3

A B C# D# C# D#  
La Si Do# Re# Do# Re#

Musical staff 3: Treble clef, whole notes with fingerings (0, 1, 2, 3, 2, 3) and solfège labels (A, B, C#, D#, C#, D#) and their corresponding syllables (La, Si, Do#, Re#, Do#, Re#).

0 1 2 3 2 3

E F# G# A# G# A#  
Mi Fa# Sol# La# Sol# La#

Musical staff 7: Treble clef, whole notes with fingerings (0, 1, 2, 3, 2, 3) and solfège labels (E, F#, G#, A#, G#, A#) and their corresponding syllables (Mi, Fa#, Sol#, La#, Sol#, La#).



0 1 2 3 4 3 4

G Sol A La B Si C# Do# D Re C# Do# D Re

0 1 2 3 4 3 4

D Re E Mi F# Fa# G# Sol# A La G# Sol# A La

0 1 2 3 4 3 4

A B C# D# E D# E  
La Si Do# Re# Mi Re# Mi

Detailed description: This block shows the first system of a musical score. It consists of a single treble clef staff with a key signature of one sharp (F#). Above the staff, fingerings are indicated by numbers 0 through 4. The notes are A, B, C#, D#, E, D#, and E. Below the staff, the notes are labeled with their solfège names: La, Si, Do#, Re#, Mi, Re#, Mi.

Detailed description: This block shows the second system of the musical score, continuing the melody from the first system. The notes are B, C#, D#, E, D#, E, D#, E.

Detailed description: This block shows the third system of the musical score, continuing the melody. The notes are E, D#, E, D#, E, D#, E, D#, E.

Detailed description: This block shows the fourth system of the musical score, continuing the melody. The notes are E, D#, E, D#, E, D#, E, D#, E.

Detailed description: This block shows the fifth system of the musical score, continuing the melody. The notes are E, D#, E, D#, E, D#, E, D#, E.

0 1 2 3 4 3 4

E F# G# A# B A# B  
Mi Fa# Sol# La# Si La# Si

Detailed description: This block shows the sixth system of the musical score. It consists of a single treble clef staff with a key signature of one sharp (F#). Above the staff, fingerings are indicated by numbers 0 through 4. The notes are E, F#, G#, A#, B, A#, and B. Below the staff, the notes are labeled with their solfège names: Mi, Fa#, Sol#, La#, Si, La#, Si.

Detailed description: This block shows the seventh system of the musical score, continuing the melody. The notes are F#, G#, A#, B, A#, B, A#, B.

Detailed description: This block shows the eighth system of the musical score, continuing the melody. The notes are B, A#, B, A#, B, A#, B, A#, B.

Detailed description: This block shows the ninth system of the musical score, continuing the melody. The notes are B, A#, B, A#, B, A#, B, A#, B.

Detailed description: This block shows the tenth system of the musical score, continuing the melody. The notes are B, A#, B, A#, B, A#, B, A#, B.

**P** 0 0 1 0 2 0 3

G D A D B D C#  
Sol Re La Re Si Re Do#

0 4 0 3 0

D D D C# D  
Re Re Re Do# Re

2 0 1 0 0

B D A D G  
Si Re La Re Sol

0 0 1 0 2 0 3 0

D A E A F# A G# A  
Re La Mi La Fa# La Sol# La

4 0 3 0 2

A A G# A F#  
La La Sol# La Fa#

0 1 0 0

A E A D  
La Mi La Re

0 0 1 0 2 0 3 0

A E B E C# E D# E  
La Mi Si Mi Do# Mi Re# Mi

4 0 3 0 2

E E D# E C#  
Mi Mi Re# Mi Do#

0 1 0 0

E B E A  
Mi Si Mi La

Q

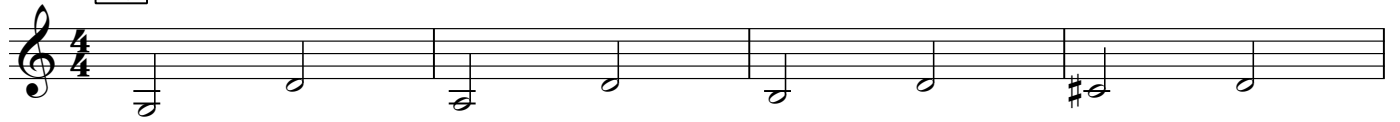

R



The next finger pattern has no semi-tones between the fingers. The semi-tone is located between the open string and the first finger. Pull the first finger back, rather than moving the entire hand a semi-tone further back. This will make it much easier to spread the hand.

**0 - Semi tone - 1 - Tone - 2 - Tone - 3 - Tone - 4**

**4th Finger  
Pattern (A)**

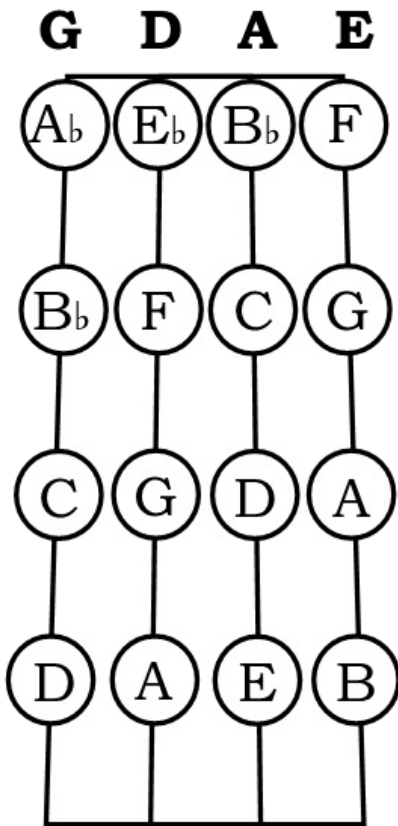

**S** 0 1 0 1 0

0 1 0 1 0

0 1 0 1 0



Musical staff with notes and accidentals.

Musical staff with notes and accidentals.

Musical staff with fingerings 0, 1, 0, 1, 0 and notes E, F, E, F.

E Mi F Fa E Mi F Fa

Musical staff with notes and accidentals.

Musical staff with notes and accidentals.

Musical staff with fingering 'T' in a box and fingerings 0, 1, 2, 1, 2, and notes G, Ab, Bb, Ab, Bb.

Sol Lab Sib Lab Sib

Musical staff with notes and accidentals.

Musical staff with notes and accidentals.

Musical staff with notes and accidentals.

Musical staff with fingerings 0, 1, 2, 1, 2 and notes D, Eb, F, Eb, F.

Re Mib Fa Mib Fa

Musical staff with notes and accidentals.



0 1 2 1 2

A Bb C Bb C  
La Sib Do Sib Do

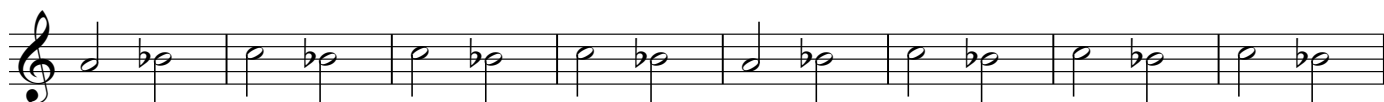

0 1 2 1 2

E F G F G  
Mi Fa Sol Fa Sol



**U** 0 1 2 3 2 3

G Sol Ab Lab Bb Sib C Do Bb Sib C Do

0 1 2 3 2 3

D Re Eb Mib F Fa G Sol F Fa G Sol

0 1 2 3 2 3

A La Bb Sib C Do D Re C Do D Re



0 1 2 3 4 3 4

D Re Eb Mib F Fa G Sol A La G Sol A La

Detailed description: This system shows a musical staff with a treble clef. It contains seven measures. Above the staff, fingerings are indicated: 0, 1, 2, 3, 4, 3, 4. Below the staff, the notes are labeled with their letter names and solfège names: D (Re), Eb (Mib), F (Fa), G (Sol), A (La), G (Sol), and A (La). A slur connects the first two notes, D and Eb.

Detailed description: This system shows a musical staff with a treble clef. It contains seven measures. The notes are: D, Eb, F, G, A, G, A.

Detailed description: This system shows a musical staff with a treble clef. It contains seven measures. The notes are: D, Eb, F, G, A, G, A.

Detailed description: This system shows a musical staff with a treble clef. It contains seven measures. The notes are: D, Eb, F, G, A, G, A.

Detailed description: This system shows a musical staff with a treble clef. It contains seven measures. The notes are: D, Eb, F, G, A, G, A.

0 1 2 3 4 3 4

A La Bb Sib C Do D Re E Mi D Re E Mi

Detailed description: This system shows a musical staff with a treble clef. It contains seven measures. Above the staff, fingerings are indicated: 0, 1, 2, 3, 4, 3, 4. Below the staff, the notes are labeled with their letter names and solfège names: A (La), Bb (Sib), C (Do), D (Re), E (Mi), D (Re), and E (Mi). A slur connects the first two notes, A and Bb.

Detailed description: This system shows a musical staff with a treble clef. It contains seven measures. The notes are: A, Bb, C, D, E, D, E.

Detailed description: This system shows a musical staff with a treble clef. It contains seven measures. The notes are: A, Bb, C, D, E, D, E.

Detailed description: This system shows a musical staff with a treble clef. It contains seven measures. The notes are: A, Bb, C, D, E, D, E.

Detailed description: This system shows a musical staff with a treble clef. It contains seven measures. The notes are: A, Bb, C, D, E, D, E.

0 1 2 3 4 3 4

E Mi F Fa G Sol A La B Si A La B Si

Detailed description: This system shows a musical staff with a treble clef. It contains seven measures. Above the staff, fingerings are indicated: 0, 1, 2, 3, 4, 3, 4. Below the staff, the notes are labeled with their letter names and solfège names: E (Mi), F (Fa), G (Sol), A (La), B (Si), A (La), and B (Si). A slur connects the first two notes, E and F.



**W**

0 0 1 0 2 0

G D Ab D Bb D

Sol Re La Re Si Re

C D D D C D

Do Re Re Re Do Re

2 0 1 0 0

Bb D Ab D G

Sib Re Lab Re Sol

D A Eb A F A

Re La Mib La Fa La

3 0 4 0 3 0

G A A A G A

Sol La La La Sol La

2 0 1 0 0

F A Eb A D

Fa La Mib La Re

0 0 1 0 2 0

A E Bb E C E

La Mi Sib Mi Do Mi

3 0 4 0 3 0

A musical staff in treble clef with a key signature of one flat (Bb). It contains six measures, each with a single note and a finger number above it: 3, 0, 4, 0, 3, 0.

D Re E Mi E Mi E Mi D Re E Mi

2 0 1 0 0

A musical staff in treble clef with a key signature of one flat (Bb). It contains five measures, each with a single note and a finger number above it: 2, 0, 1, 0, 0.

C Do X E Mi Bb Sib E Mi A La

A musical staff in treble clef with a key signature of one flat (Bb) and a 4/4 time signature. It contains six measures of music with various note values and accidentals.

A musical staff in treble clef with a key signature of one flat (Bb). It contains six measures of music with various note values and accidentals.

A musical staff in treble clef with a key signature of one flat (Bb). It contains six measures of music with various note values and accidentals.

A musical staff in treble clef with a key signature of one flat (Bb). It contains six measures of music with various note values and accidentals.

A musical staff in treble clef with a key signature of one flat (Bb). It contains six measures of music with various note values and accidentals.

A musical staff in treble clef with a key signature of one flat (Bb). It contains six measures of music with various note values and accidentals.

Y

A musical staff in treble clef with a key signature of one flat (Bb) and a 4/4 time signature. It contains six measures of music with various note values and accidentals.

A musical staff in treble clef with a key signature of one flat (Bb). It contains six measures of music with various note values and accidentals.

A musical staff in treble clef with a key signature of one flat (Bb). It contains six measures of music with various note values and accidentals.

This next finger pattern has no semi-tones at all. Every interval is a tone. To make it easier for the fourth finger to reach, place the thumb approx. opposite your second finger and pull back the first finger.

**0 - Tone - 1 - Tone - 2 - Tone - 3 - Tone - 4**

### 4th Finger Pattern (B)

**G D A E**

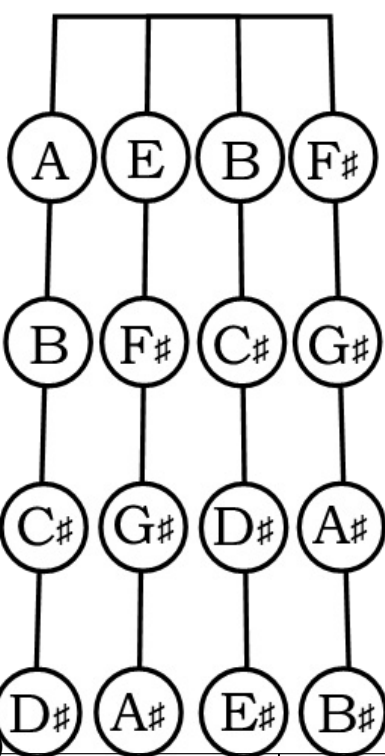

**Z** 0 1 2 3 4

G Sol A La B Si C# Do# D# Re#

C# Do# D# Re#

0 1 2 3 4 3 4

D Re E Mi F# Fa# G# Sol# A# La# G# Sol# A# La#





The image displays two staves of musical notation. The first staff contains a sequence of notes with sharp accidentals, organized into five measures. The second staff contains a sequence of notes with sharp accidentals, organized into five measures, followed by a final measure with a whole note and a double bar line. The notes in both staves appear to be eighth notes, and the sharp accidentals suggest a key signature of one sharp (F#).