

CHAPTER 3

Scales in the First Position

Charles de Beriot
From: Methode de violin, Op. 102

The finger patterns before each scale show all notes of that Key in first position. It does not limit itself to the notes used in the scales themselves.

The Blue notes are potential alternative fingerings. A high fourth finger can also be played as a low first finger on the next string up. This will then lead to a completely different finger pattern. I recommend, once you are proficient with a scale, to experiment with the alternatives.

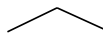
To help out, all semi-tones have been marked with 

C MAJOR

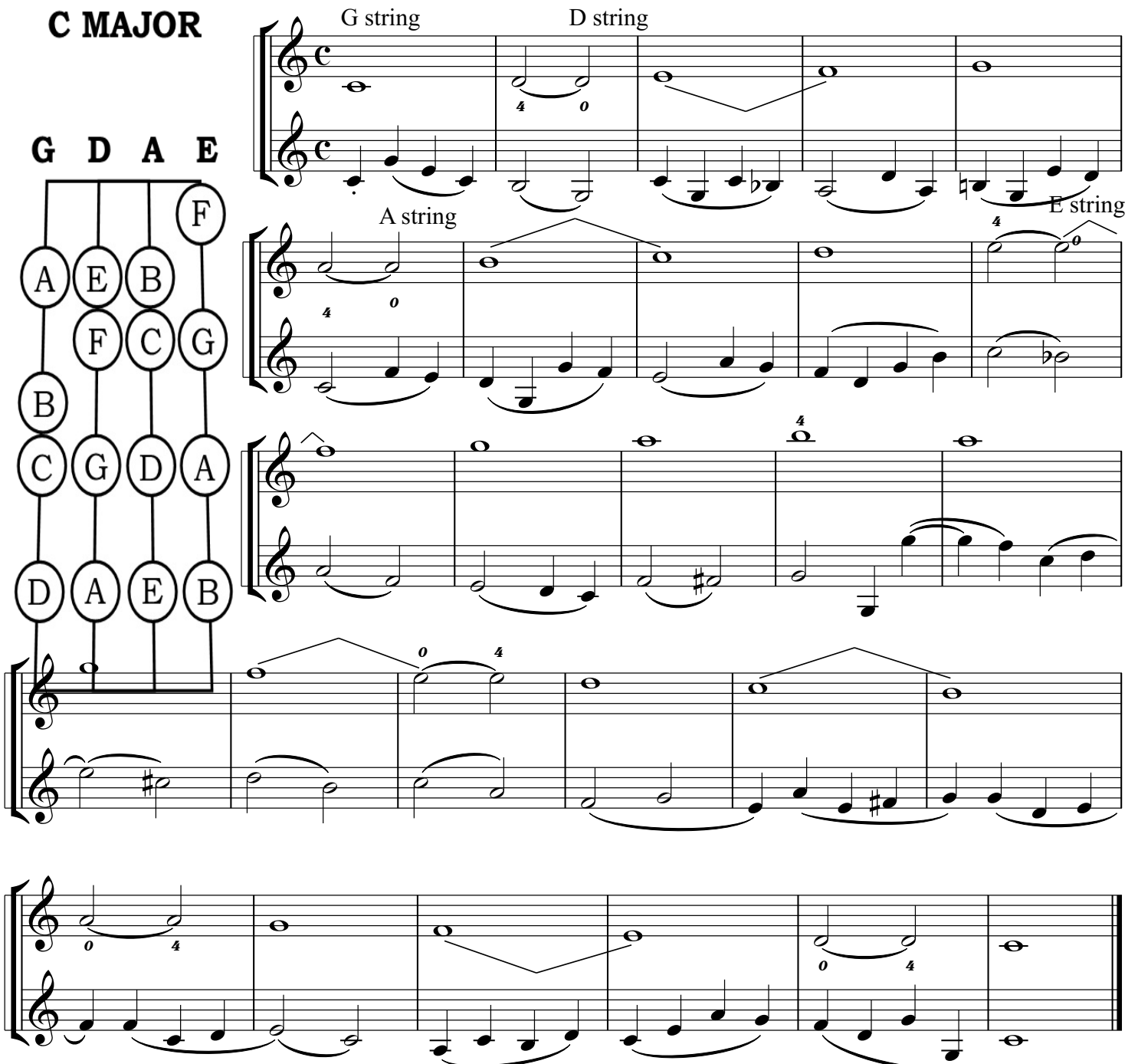

The musical score for C Major scales in first position is presented in four systems. Each system consists of two staves: the upper staff for the G string and D string, and the lower staff for the A string and E string. The scales are written in treble clef with a common time signature (C). Fingerings are indicated by numbers 1-4 and 0 (open string). Blue notes indicate alternative fingerings. Bent lines above notes indicate semi-tones. The first system shows the ascending and descending scales. The second system shows the ascending and descending scales with alternative fingerings. The third system shows the ascending and descending scales with alternative fingerings. The fourth system shows the ascending and descending scales with alternative fingerings.

Fingerings:

String	Notes	Fingerings
G string	G, A, B, C, D, E, F, G	1, 2, 3, 4, 0, 4, 3, 2, 1
D string	D, E, F, G, A, B, C, D	1, 2, 3, 4, 0, 4, 3, 2, 1
A string	A, B, C, D, E, F, G, A	1, 2, 3, 4, 0, 4, 3, 2, 1
E string	E, F, G, A, B, C, D, E	1, 2, 3, 4, 0, 4, 3, 2, 1

A MINOR

melodic up

G D A E

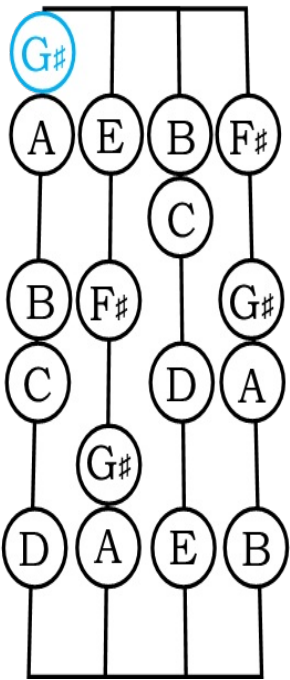

A MINOR

melodic down

G D A E

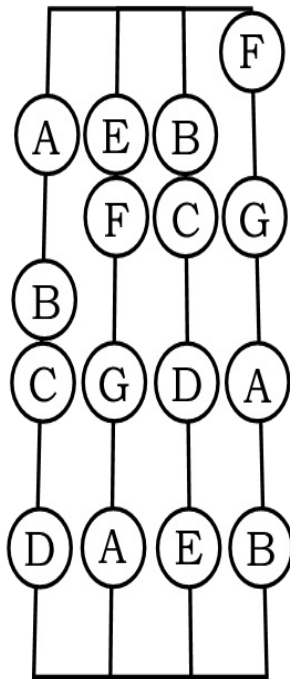

G MAJOR

G D A E

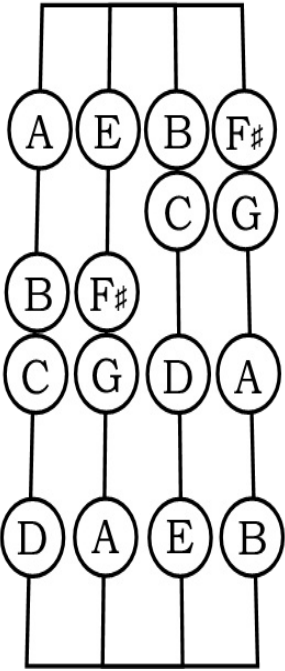

First system of musical notation for G major. It consists of two staves in treble clef with a key signature of one sharp (F#) and a common time signature (C). The melody is on the top staff, and the bass line is on the bottom staff. The melody starts with a G4 (open string), followed by A4, B4, C5, D5, E5, and then a descending sequence: D5, C5, B4, A4, G4. The bass line starts with a G3 (open string), followed by A3, B3, C4, D4, E4, and then a descending sequence: D4, C4, B3, A3, G3. There are some fingerings indicated: '0' for open strings and '4' for the 4th fret.

Second system of musical notation for G major. It consists of two staves in treble clef with a key signature of one sharp (F#) and a common time signature (C). The melody is on the top staff, and the bass line is on the bottom staff. The melody continues with D5, C5, B4, A4, G4, and then a descending sequence: F#4, E4, D4, C4, B3, A3, G3. The bass line continues with F#3, E3, D3, C3, B2, A2, G2. There are some fingerings indicated: '4' for the 4th fret and '0' for open strings.

Third system of musical notation for G major. It consists of two staves in treble clef with a key signature of one sharp (F#) and a common time signature (C). The melody is on the top staff, and the bass line is on the bottom staff. The melody continues with G4, A4, B4, C5, D5, E5, and then a descending sequence: D5, C5, B4, A4, G4. The bass line continues with F#3, E3, D3, C3, B2, A2, G2. There are some fingerings indicated: '4' for the 4th fret and '0' for open strings.

Fourth system of musical notation for G major. It consists of two staves in treble clef with a key signature of one sharp (F#) and a common time signature (C). The melody is on the top staff, and the bass line is on the bottom staff. The melody continues with G4, A4, B4, C5, D5, E5, and then a descending sequence: D5, C5, B4, A4, G4. The bass line continues with F#3, E3, D3, C3, B2, A2, G2. There are some fingerings indicated: '0' for open strings and '4' for the 4th fret.

Fifth system of musical notation for G major. It consists of two staves in treble clef with a key signature of one sharp (F#) and a common time signature (C). The melody is on the top staff, and the bass line is on the bottom staff. The melody continues with G4, A4, B4, C5, D5, E5, and then a descending sequence: D5, C5, B4, A4, G4. The bass line continues with F#3, E3, D3, C3, B2, A2, G2. There are some fingerings indicated: '0' for open strings and '4' for the 4th fret.

Sixth system of musical notation for G major. It consists of two staves in treble clef with a key signature of one sharp (F#) and a common time signature (C). The melody is on the top staff, and the bass line is on the bottom staff. The melody continues with G4, A4, B4, C5, D5, E5, and then a descending sequence: D5, C5, B4, A4, G4. The bass line continues with F#3, E3, D3, C3, B2, A2, G2. There are some fingerings indicated: '0' for open strings and '4' for the 4th fret.

E MINOR

melodic up

G D A E

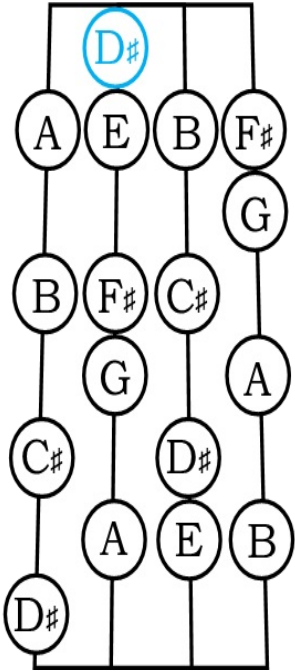

E MINOR

melodic down

G D A E

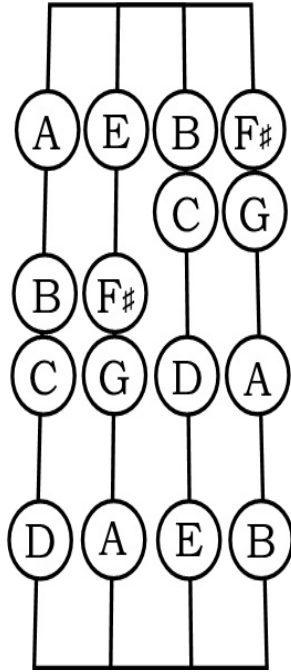

The first system of music consists of two staves. The top staff is in treble clef with a key signature of one sharp (F#) and a 4/4 time signature. It contains two measures: the first measure has a quarter note G4 with a fermata above it, and the second measure has a quarter note A4 with a fermata above it. The bottom staff also has a key signature of one sharp and a 4/4 time signature. It contains two measures of accompaniment. The first measure starts with a quarter rest, followed by an eighth note G3, a quarter note A3, and a quarter note B3. The second measure starts with a quarter rest, followed by an eighth note A3, a quarter note B3, and a quarter note C4. There are slurs and ties connecting notes across the measures.

The second system of music consists of two staves. The top staff is in treble clef with a key signature of one sharp (F#) and a 4/4 time signature. It contains three measures: the first measure has a quarter note G4, the second measure has a quarter note A4, and the third measure has a quarter note B4 with a fermata above it. The bottom staff also has a key signature of one sharp and a 4/4 time signature. It contains three measures of accompaniment. The first measure starts with a quarter rest, followed by an eighth note G3, a quarter note A3, and a quarter note B3. The second measure starts with a quarter rest, followed by an eighth note A3, a quarter note B3, and a quarter note C4. The third measure starts with a quarter rest, followed by an eighth note B3, a quarter note C4, and a quarter note D4. There are slurs and ties connecting notes across the measures.

D MAJOR

G D A E

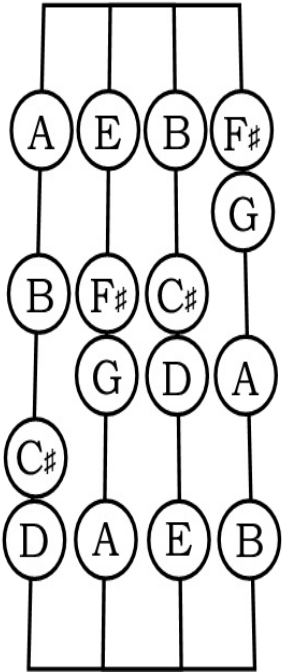

B MINOR

melodic up

G D A E

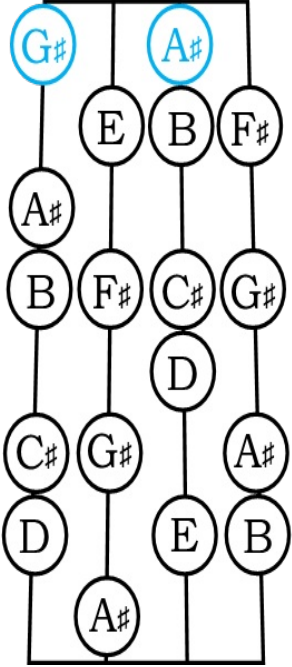

B MINOR

melodic down

G D A E

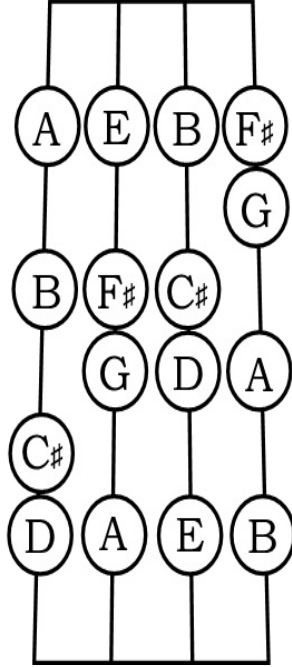

Musical notation for the first system, showing a treble and bass clef staff in B minor with a 'dolce' marking.

Musical notation for the second system, showing a treble and bass clef staff with a 4-measure rest in the bass staff.

Musical notation for the third system, showing a treble and bass clef staff with a 4-measure rest in the bass staff.

Musical notation for the fourth system, showing a treble and bass clef staff with a 4-measure rest in the bass staff.

Musical notation for the fifth system, showing a treble and bass clef staff with a 4-measure rest in the bass staff.

Musical notation for the sixth system, showing a treble and bass clef staff with a 4-measure rest in the bass staff.

First system of musical notation in A major, consisting of a treble and bass staff. The treble staff contains a sequence of quarter notes: A4, B4, C#5, D5, E5, D5, C#5, B4, A4. The bass staff contains a sequence of eighth notes: A3, G3, F#3, E3, D3, C#3, B2, A2. There are slurs and fingerings (0, 4) indicated.

Second system of musical notation in A major, consisting of a treble and bass staff. The treble staff contains a sequence of quarter notes: A4, B4, C#5, D5, E5, D5, C#5, B4, A4. The bass staff contains a sequence of eighth notes: A3, G3, F#3, E3, D3, C#3, B2, A2. There are slurs and fingerings (0, 4) indicated.

Third system of musical notation in A major, consisting of a treble and bass staff. The treble staff contains a sequence of quarter notes: A4, B4, C#5, D5, E5, D5, C#5, B4, A4. The bass staff contains a sequence of eighth notes: A3, G3, F#3, E3, D3, C#3, B2, A2. There are slurs and fingerings (0, 4) indicated.

A MAJOR

G D A E

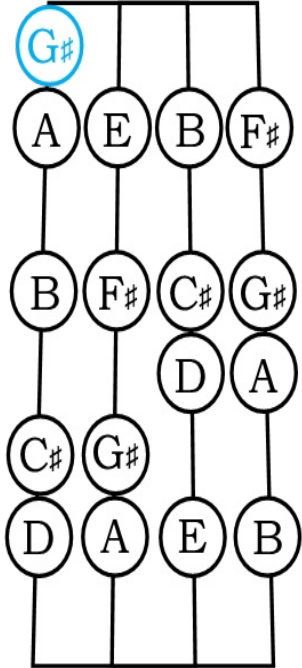

First system of musical notation for the A major section, consisting of a treble and bass staff. The treble staff contains a sequence of quarter notes: A4, B4, C#5, D5, E5, D5, C#5, B4, A4. The bass staff contains a sequence of eighth notes: A3, G3, F#3, E3, D3, C#3, B2, A2. There are slurs and fingerings (0, 4) indicated.

Second system of musical notation for the A major section, consisting of a treble and bass staff. The treble staff contains a sequence of quarter notes: A4, B4, C#5, D5, E5, D5, C#5, B4, A4. The bass staff contains a sequence of eighth notes: A3, G3, F#3, E3, D3, C#3, B2, A2. There are slurs and fingerings (0, 4) indicated.

Third system of musical notation for the A major section, consisting of a treble and bass staff. The treble staff contains a sequence of quarter notes: A4, B4, C#5, D5, E5, D5, C#5, B4, A4. The bass staff contains a sequence of eighth notes: A3, G3, F#3, E3, D3, C#3, B2, A2. There are slurs and fingerings (0, 4) indicated.

First system of musical notation. The treble clef staff contains a melodic line with a slur over the first two notes and a 4-fingered chord marked '4' above the third note. The bass clef staff contains a rhythmic accompaniment of eighth notes.

Second system of musical notation. The treble clef staff continues the melodic line with a slur. The bass clef staff continues the accompaniment, featuring a trill marked 'tr' in the final measure.

Third system of musical notation. The treble clef staff has a slur over the first two notes and a 4-fingered chord marked '4' above the third note. The bass clef staff continues the accompaniment with a trill marked 'tr' in the final measure.

Fourth system of musical notation. The treble clef staff has a slur over the first two notes and a 4-fingered chord marked '4' above the third note. The bass clef staff continues the accompaniment with a 4-fingered chord marked '4' above the third note.

Fifth system of musical notation. The treble clef staff has a slur over the first two notes and a 4-fingered chord marked '4' above the third note. The bass clef staff features a trill marked 'tr' in the first measure and another trill marked 'tr' in the fourth measure.

Sixth system of musical notation. The treble clef staff has a slur over the first two notes. The bass clef staff continues the accompaniment. The system concludes with a double bar line.

F# MINOR

melodic up

G D A E

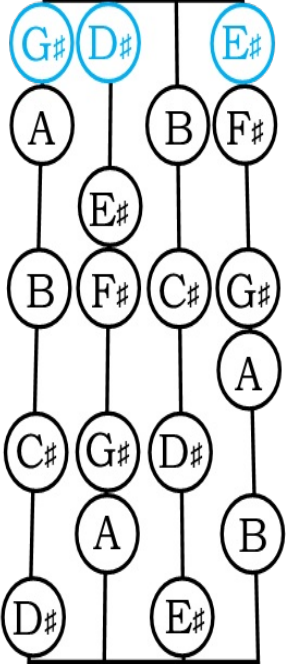

F# MINOR

melodic down

G D A E

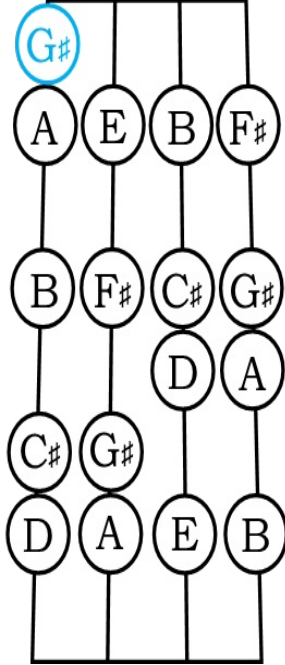

0 4

E MAJOR

G D A E

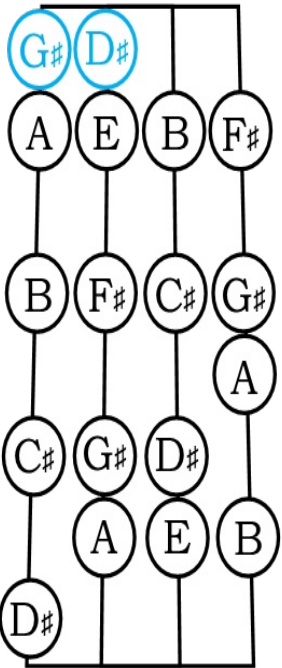

V 4 0

4 0

4 0

4 0

0 4

F MAJOR

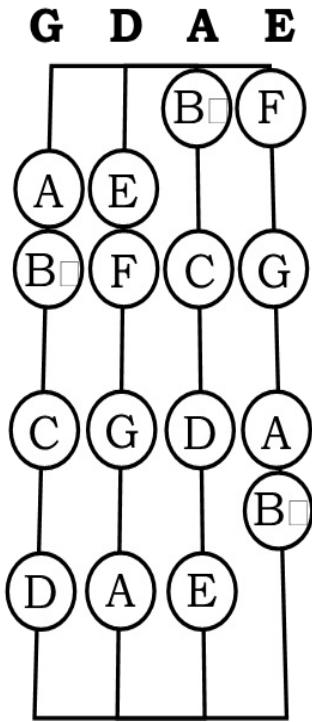

The musical notation consists of three systems, each with a treble and bass clef staff. The first system shows the scale in a simple, stepwise fashion. The second system shows the scale with various phrasing slurs and accents. The third system shows the scale with more complex phrasing, including a fermata on the final note.

D MINOR

melodic up

G D A E

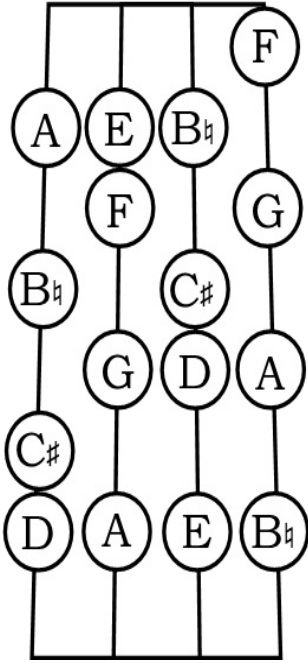

D MINOR

melodic down

G D A E

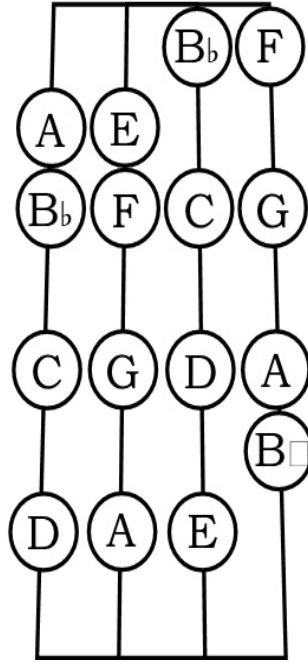

B \flat MAJOR

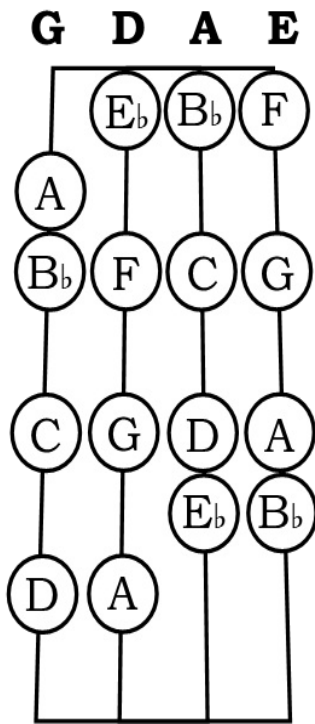

C MINOR

melodic up

G D A E

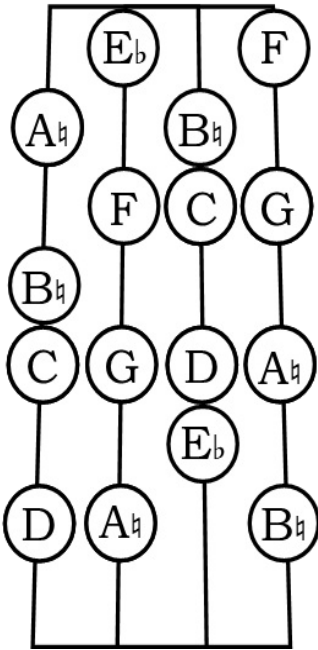

C MINOR

melodic down

G D A E

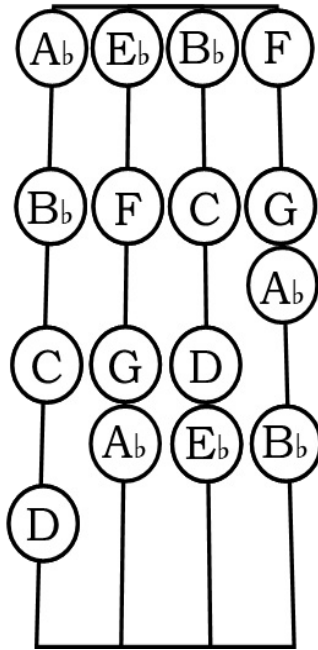

A \flat MAJOR

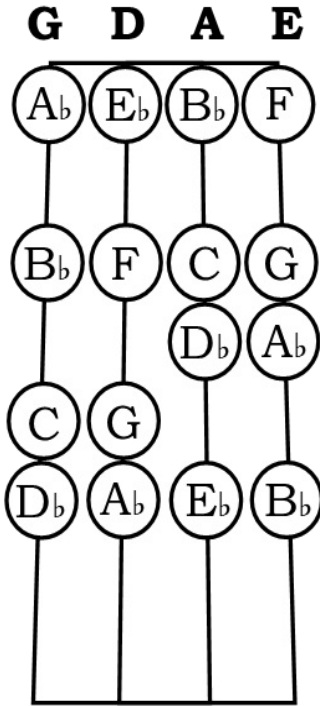

F MINOR

melodic up

F MINOR

melodic down

G D A E

G D A E

