

# CHAPTER 3

## Scales in the First Position

Charles de Beriot  
From: Methode de violon, Op. 102

The finger patterns before each scale show all notes of that Key in first position. It does not limit itself to the notes used in the scales themselves.

The Blue notes are potential alternative fingerings. A high fourth finger can also be played as a low first finger on the next string up. This will then lead to a completely different finger pattern. I recommend, once you are proficient with a scale, to experiment with the alternatives.

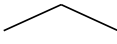
To help out, all semi-tones have been marked with 

### C MAJOR

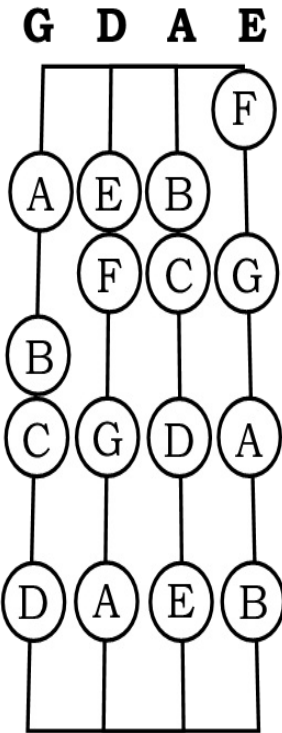

3 4 0 1 2 3

C Do D Re E Mi F Fa G Sol

4 0 1 2 3 4 0

A La B Si C Do D Re E Mi F Fa G Sol A La

1 2 3 4 3

F Fa G Sol A La B Si C Do D Re E Mi F Fa

2 1 0 4 3 2 1

G Sol F Fa E Mi D Re C Do B Si A La G Sol

0 4 3 2 1 0 4 3  
 A La G Sol F Fa E Mi D Re C Do

**A MINOR**

**melodic up**

**G D A E**

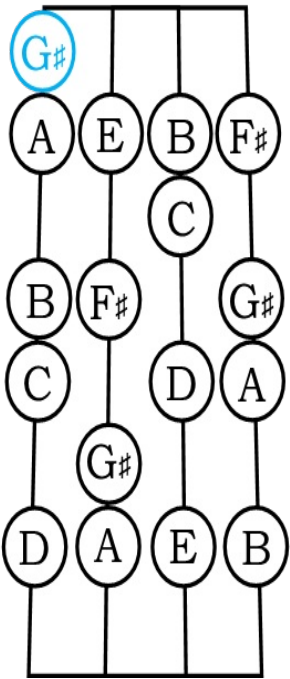

**A MINOR**

**melodic down**

**G D A E**

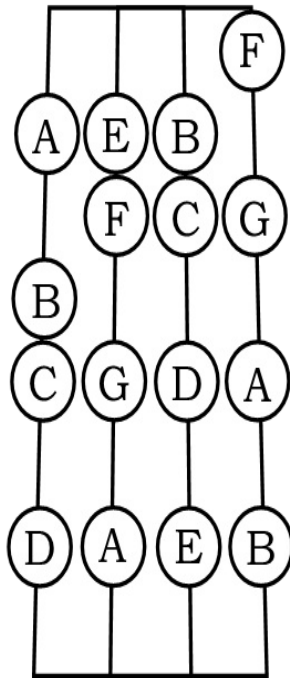

1 2 3  
 C Do B Si C Do

4 0 1 2  
 D Re E Mi F# Fa#

3 4 0 1  
 G# Sol# A La B Si

2 3 4 0 1 2 3 4  
 C Do D Re E Mi F# Fa# G# Sol# A La B Si

3 2 1 4 0 3 2 1  
 A La G Sol F Fa E Mi D Re C Do B Si

0 4 3 2 1

A La G Sol F Fa E Mi

0 4 3 2 1

D Re C Do B Si A La

### G MAJOR

G D A E

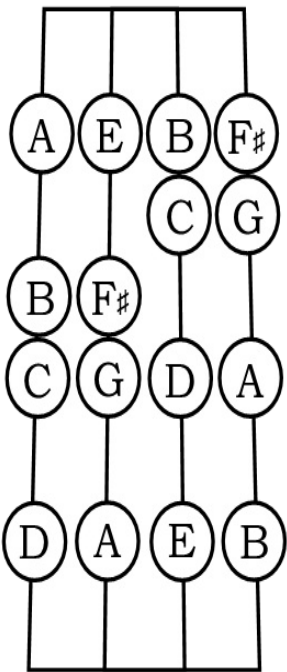

0 1 2 3 4 0

G Sol A La B Si C Do D Re

1 2 3 4 0 1

E Mi F# Fa# G Sol A La B Si

2 3 4 0 1 2

C Do D Re E Mi F# Fa# G Sol

3 4 3 2 1 0 4 3

A La B Si A La G Sol F# Fa# E Mi D Re

2 1 0 4 3 2 1

C Do B Si A La G Sol F# Fa# E Mi

0 4 3 2 1 0

D Re C Do B Si A La G Sol

### E MINOR

melodic up

G D A E

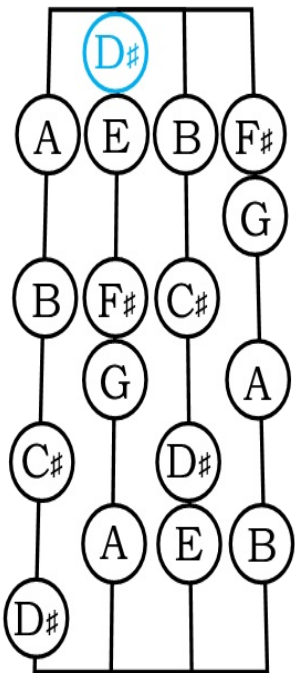

### E MINOR

melodic down

G D A E

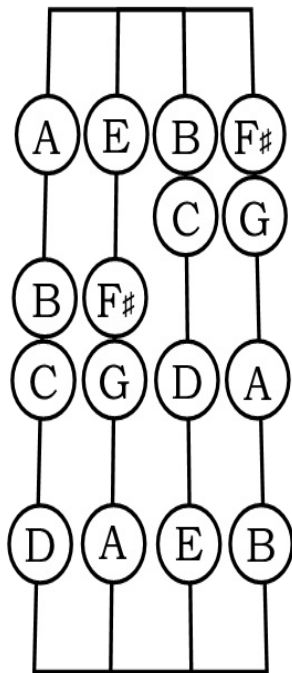

1 2

E Mi F# Fa#

3 4 0

G Sol A La

1 2

B Si C# Do#

3 4 0 1 2

D#  
Re#

E  
Mi

F#  
Fa#

G  
Sol

This system contains the first four measures of the piece. The top staff shows a sequence of notes: D# (finger 3), E (finger 4), F# (finger 0), and G (finger 2). The bottom staff features a rhythmic accompaniment of eighth notes.

3 4 3 2

A  
La

B  
Si

A  
La

G  
Sol

This system contains measures 5 through 8. The top staff notes are A (finger 3), B (finger 4), A (finger 3), and G (finger 2). The bottom staff continues the rhythmic accompaniment.

1 0 4 3 2

F#  
Fa#

E  
Mi

D  
Re

C  
Do

This system contains measures 9 through 12. The top staff notes are F# (finger 1), E (finger 0), D (finger 4), and C (finger 2). The bottom staff continues the rhythmic accompaniment.

1 0 4

B  
Si

A  
La

This system contains measures 13 through 16. The top staff notes are B (finger 1), A (finger 0), and A (finger 4). The bottom staff continues the rhythmic accompaniment.

3 2 1

G  
Sol

F#  
Fa#

E  
Mi

This system contains the final three measures of the piece. The top staff notes are G (finger 3), F# (finger 2), and E (finger 1). The bottom staff concludes the rhythmic accompaniment.

# D MAJOR

G D A E

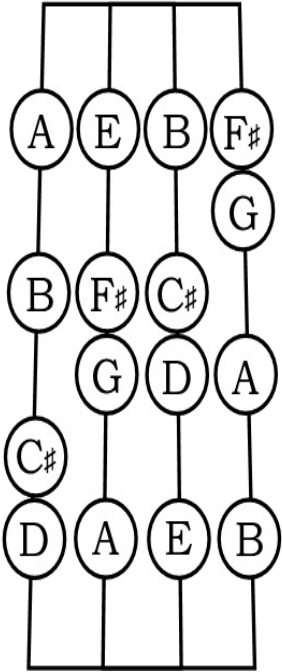

0 1 2 3 4 0

D Re E Mi F# Fa# G Sol A La

1 2 3 4 0 1

B Si C# Do# D Re E Mi F# Fa#

2 3 4 3 2

G Sol A La B Si A La G Sol

1 0 4 3 2 1

F# Fa# E Mi D Re C# Do# B Si

0 4 3 2 1 0

A La G Sol F# Fa# E Mi D Re

### B MINOR

melodic up

G D A E

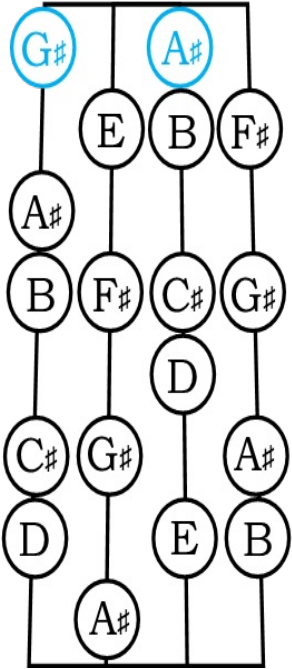

### B MINOR

melodic down

G D A E

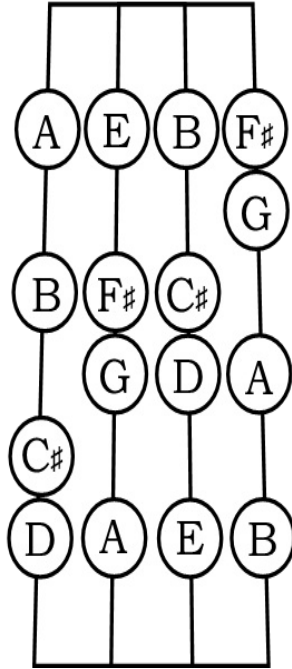

1 0 4 3 2

F# Fa E Mi D Re C# Do#

1 0 4 3 2

B Si A La G Sol F# Fa#

1 0 4 3 2

E Mi D Re C# Do# B Si

### A MAJOR

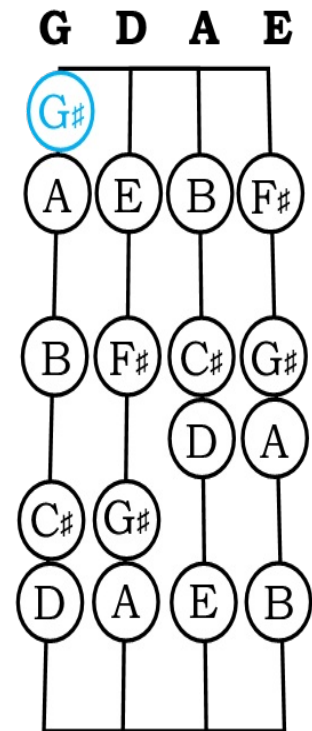

1 2 3

A La B Si C# Do#

4 0 1 2

D Re E Mi F# Fa#

3 4 0 1

G# Sol# A La B Si



2 3 4 0 1

C# Do# D Re E Mi F# Fa#

2 3 4 3

G# Sol# A La B Si A La

2 1 0 4 3

G# Sol# F# Fa# E Mi D Re

2 1 0 4 3

C# Do# B Si A La G# Sol#

2 1 0 4

F# Fa# E Mi D Re

3 2 1

C# Do# B Si A La

**F# MINOR**

**melodic up**

**G D A E**

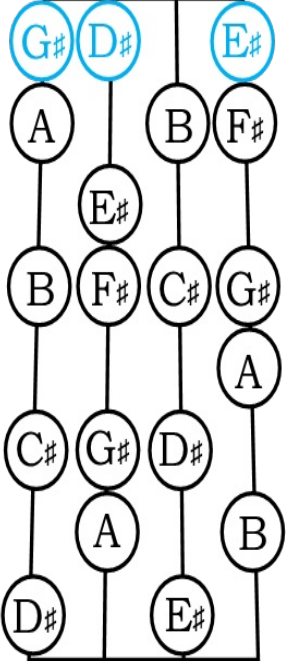

**F# MINOR**

**melodic down**

**G D A E**

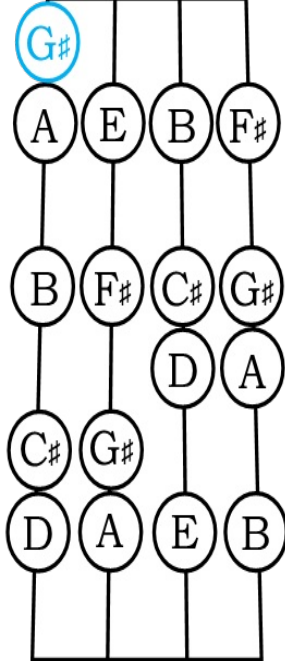

0 4 3 2

A La G# Sol# F# Fa#

### E MAJOR

G D A E

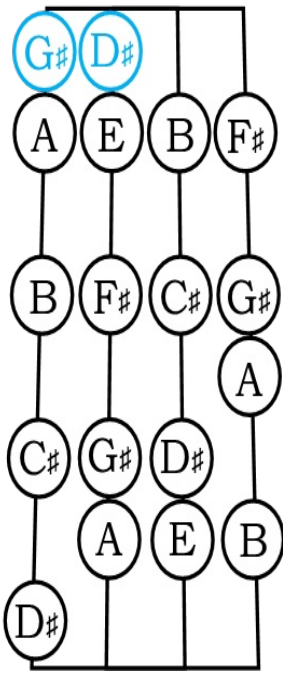

1 2 3 4 0

E Mi F# Fa# G# Sol# A La

1 2 3 4 0

B Si C# Do# D# Re# E Mi

1 2 3 4

F# Fa# G# Sol# A La B Si

3 2 1 0 4 3

A La G# Sol# F# Fa# E Mi D# Re#

2 1 0 4 3 2 1

C# Do# B Si A La G# Sol# F# Fa# E Mi

**C# MINOR**

**melodic up**

**G D A E**

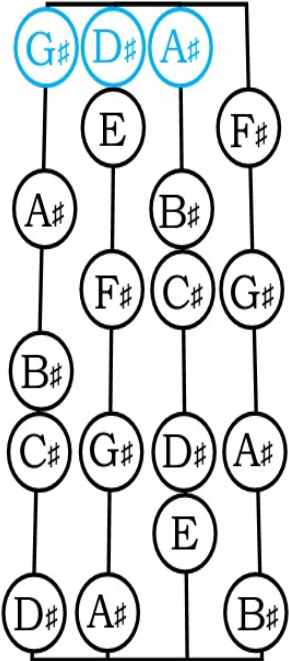

**C# MINOR**

**melodic down**

**G D A E**

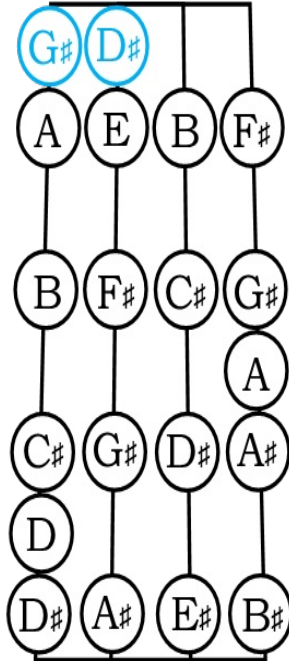

# F MAJOR

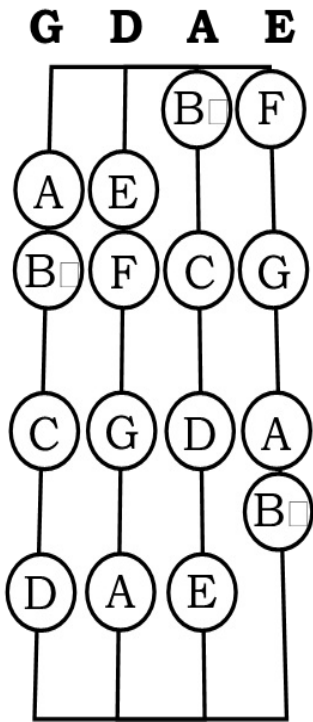

**System 1:**

Vocal: F Fa, G Sol, A La, B $\flat$  Sib, C Do, D Re, E Mi, F Fa

Guitar: F, G, A, B $\flat$ , C, D, E, F

**System 2:**

Vocal: G Sol, A La, B $\flat$  Sib, A La, G Sol, F Fa

Guitar: G, A, B $\flat$ , A, G, F

**System 3:**

Vocal: E Mi, D Re, C Do, B $\flat$  Sib, A La, G Sol, F Fa

Guitar: E, D, C, B $\flat$ , A, G, F

**D MINOR**

**melodic up**

**G D A E**

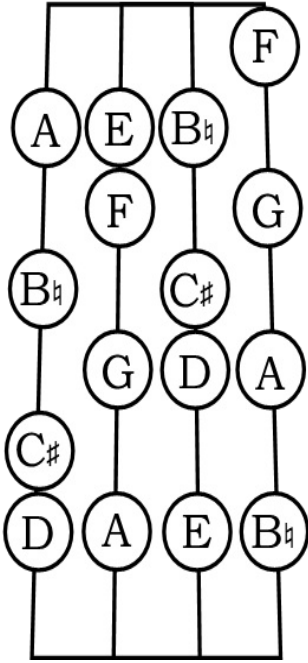

**D MINOR**

**melodic down**

**G D A E**

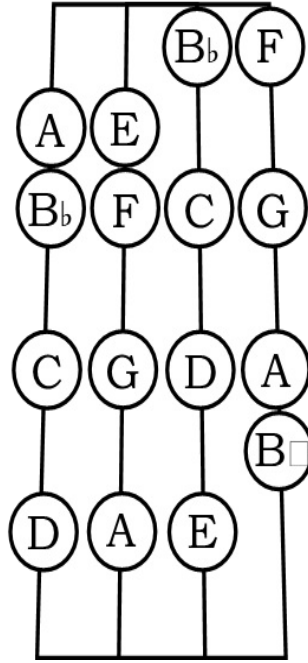

# B $\flat$ MAJOR

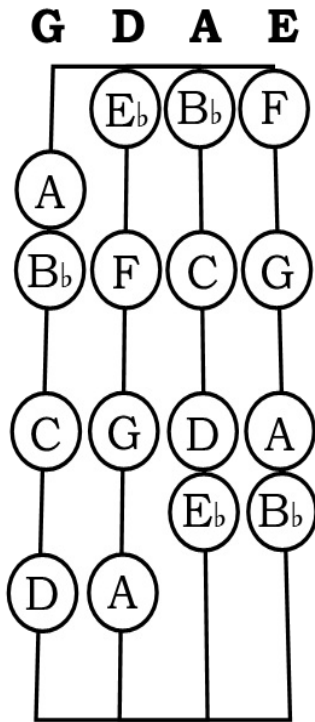

2 3 4 1 2 3 4 1 2 3 4 1

2 3 4 3 2 1 4 3

2 1 4 3 2 1 4 3 2

### G MINOR

#### melodic up

G D A E

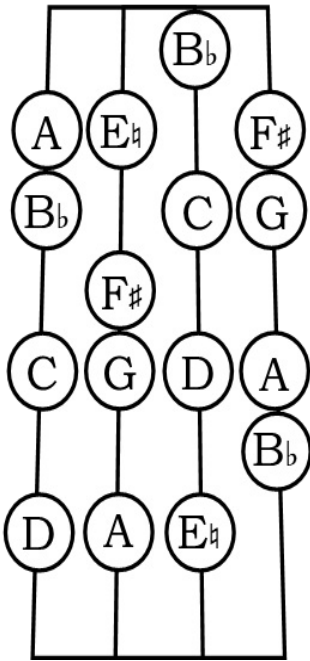

### G MINOR

#### melodic down

G D A E

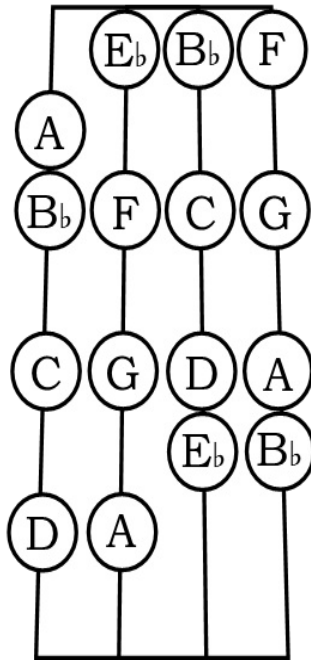



# E<sub>b</sub> MAJOR

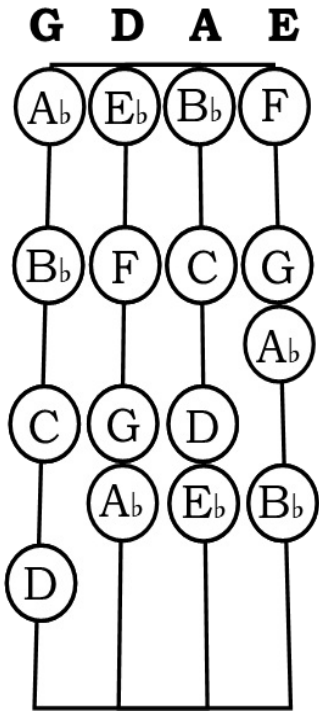

1 2 3 4

E Mi F Fa G Sol Ab Lab

1 2 3 4

B<sub>b</sub> Sib C Do D Re E<sub>b</sub> Mib

1 2 3 4

F Fa G Sol Ab Lab B<sub>b</sub> Sib

3 2 1 4 3

Ab Lab G Sol F Fa E<sub>b</sub> Mib D Re

2 1 4 3 2 1

C Do B<sub>b</sub> Sib Ab Lab G Sol F Fa E<sub>b</sub> Mib

**C MINOR**

**melodic up**

**G D A E**

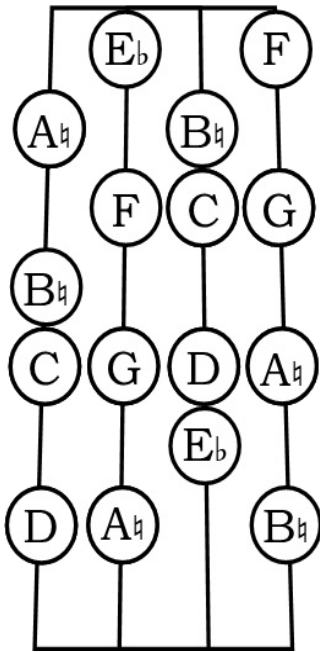

**C MINOR**

**melodic down**

**G D A E**

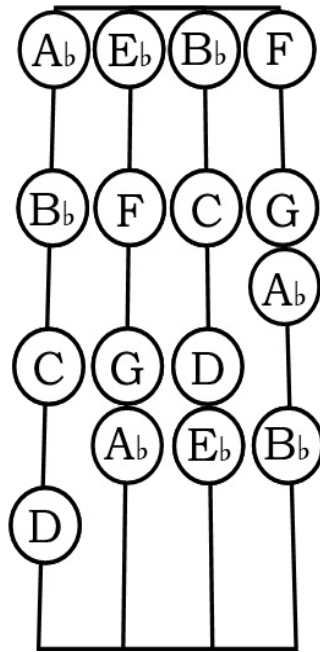

D Re C Do Bb Sib Ab Lab

G Sol F Fa Eb Mib D Re C Do

### Ab MAJOR

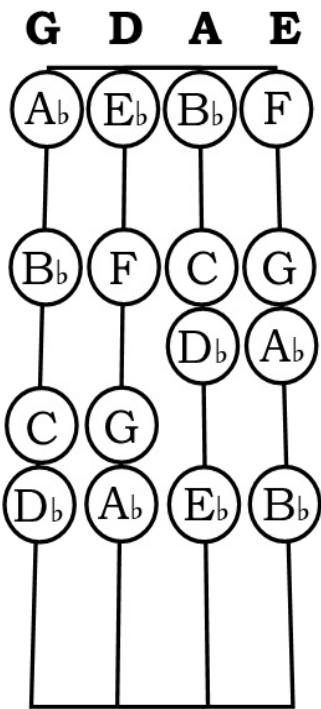

A La Bb Sib C Do

Db Reb Eb Mib F Fa

G Sol Ab Lab Bb Sib

C Do Db Reb Eb Mib F Fa G Sol

**F MINOR**  
melodic up

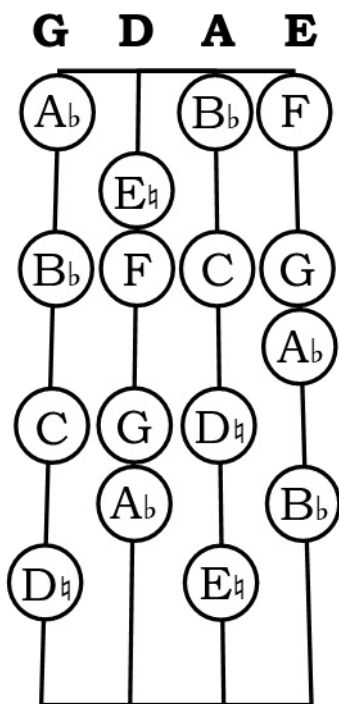

**F MINOR**  
melodic down

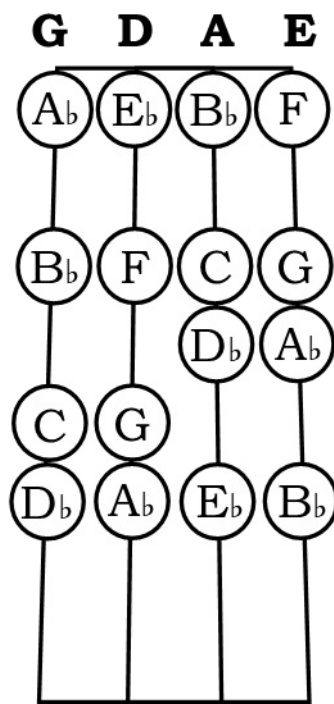

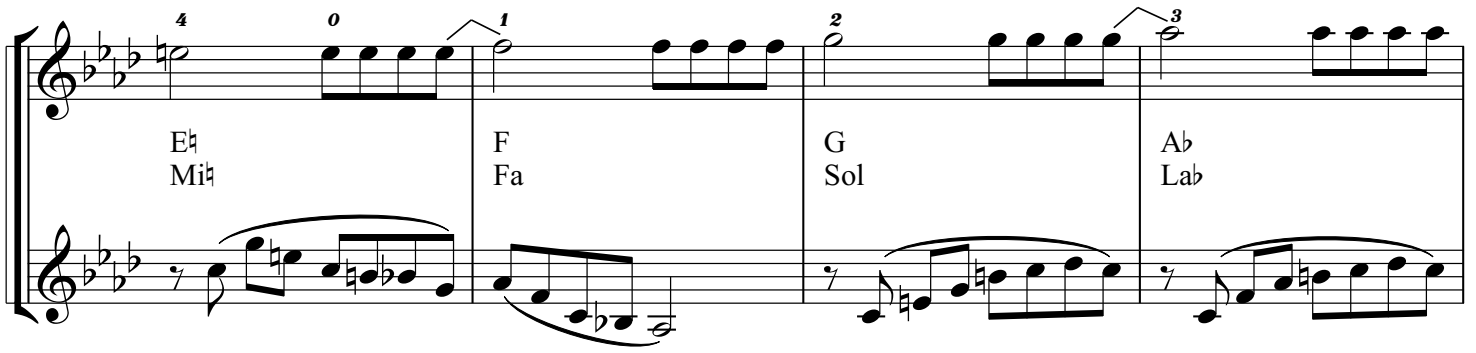

4 0 1 2 3

E $\flat$  Mi $\flat$  F Fa G Sol A $\flat$  La $\flat$

This system contains two staves of music. The upper staff features a sequence of chords: E $\flat$  Mi $\flat$ , F Fa, G Sol, and A $\flat$  La $\flat$ . Above the notes are fingerings: 4, 0, 1, 2, and 3. The lower staff contains a melodic line with slurs and rests.

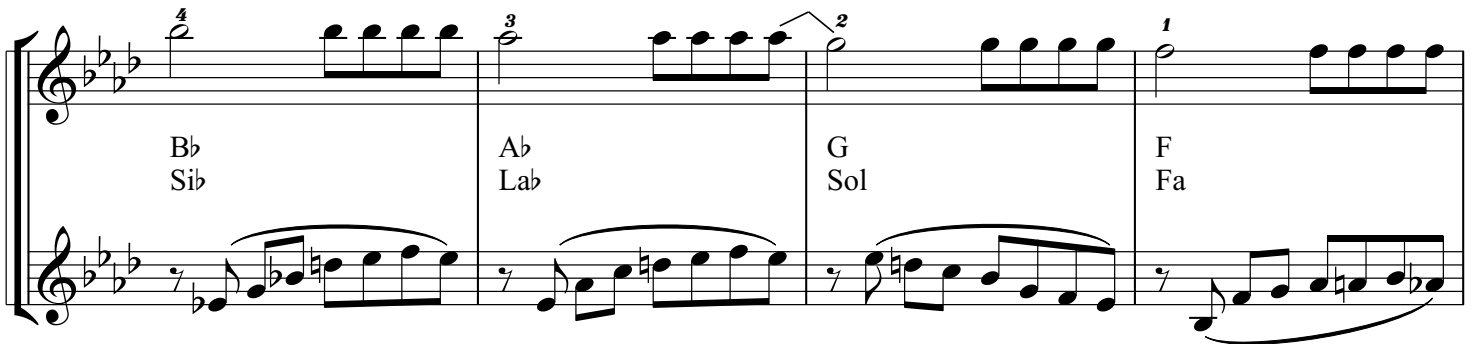

4 3 2 1

B $\flat$  Si $\flat$  A $\flat$  La $\flat$  G Sol F Fa

This system contains two staves of music. The upper staff features a sequence of chords: B $\flat$  Si $\flat$ , A $\flat$  La $\flat$ , G Sol, and F Fa. Above the notes are fingerings: 4, 3, 2, and 1. The lower staff contains a melodic line with slurs and rests.

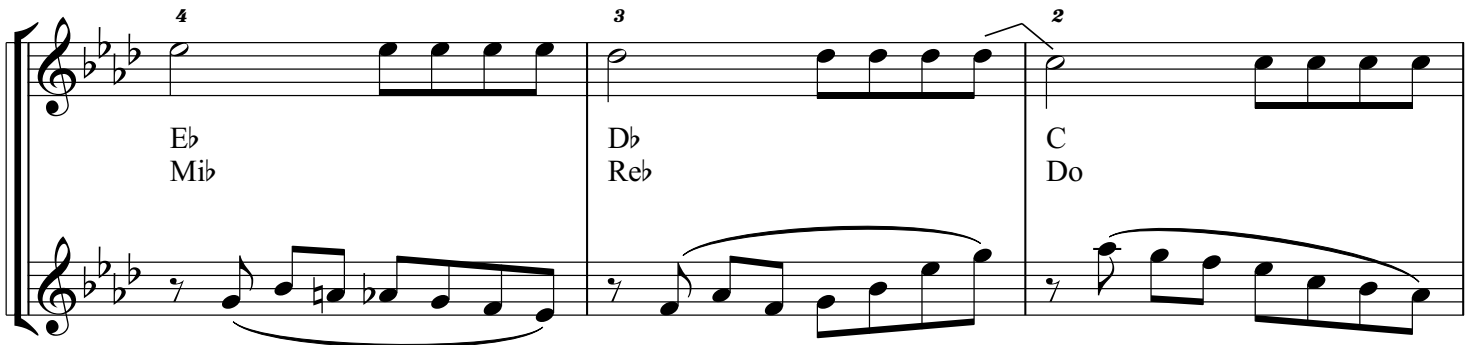

4 3 2

E $\flat$  Mi $\flat$  D $\flat$  Re $\flat$  C Do

This system contains two staves of music. The upper staff features a sequence of chords: E $\flat$  Mi $\flat$ , D $\flat$  Re $\flat$ , and C Do. Above the notes are fingerings: 4, 3, and 2. The lower staff contains a melodic line with slurs and rests.

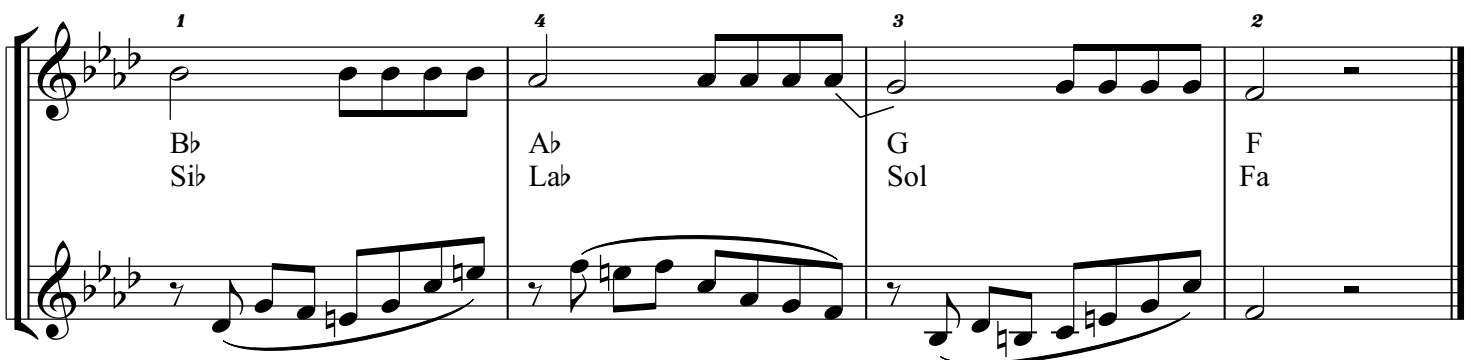

1 4 3 2

B $\flat$  Si $\flat$  A $\flat$  La $\flat$  G Sol F Fa

This system contains two staves of music. The upper staff features a sequence of chords: B $\flat$  Si $\flat$ , A $\flat$  La $\flat$ , G Sol, and F Fa. Above the notes are fingerings: 1, 4, 3, and 2. The lower staff contains a melodic line with slurs and rests.