

CHAPTER 3

Scales in the First Position

Charles de Beriot
From: Methode de violin, Op. 102

The finger patterns before each scale show all notes of that Key in first position. It does not limit itself to the notes used in the scales themselves.

The Blue notes are potential alternative fingerings. A high fourth finger can also be played as a low first finger on the next string up. This will then lead to a completely different finger pattern. I recommend, once you are proficient with a scale, to experiment with the alternatives.

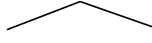
To help out, all semi-tones have been marked with 

C MAJOR

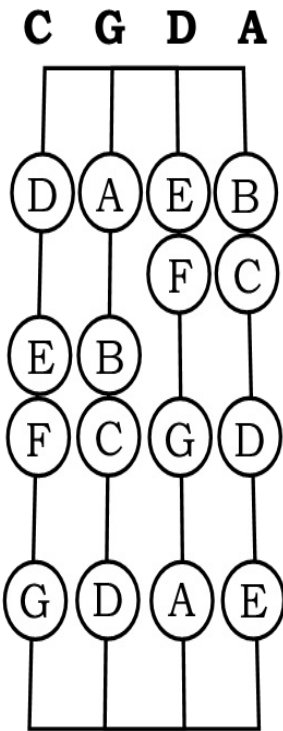
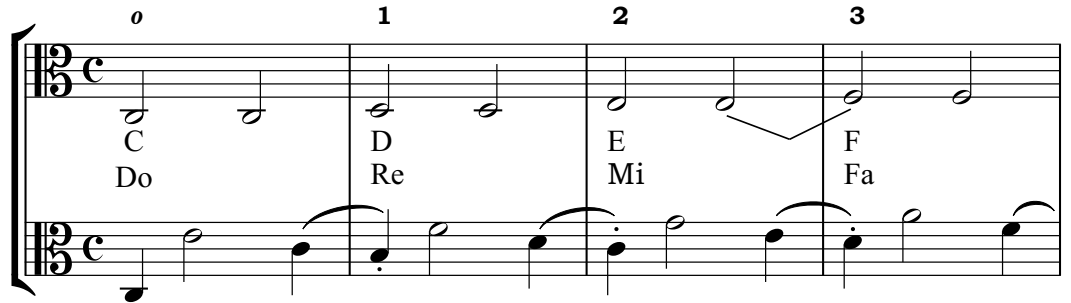
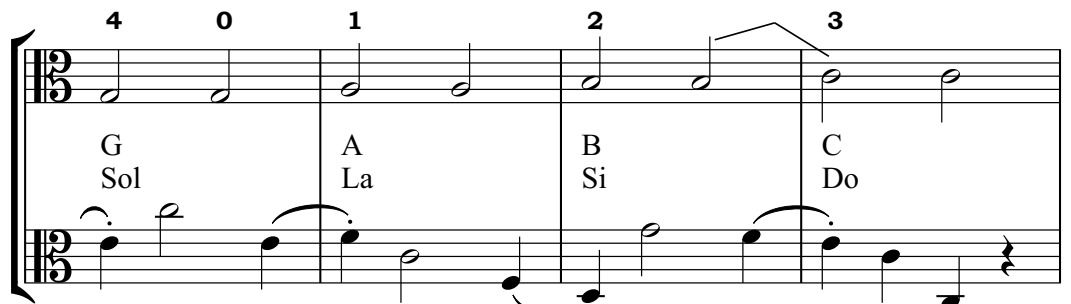
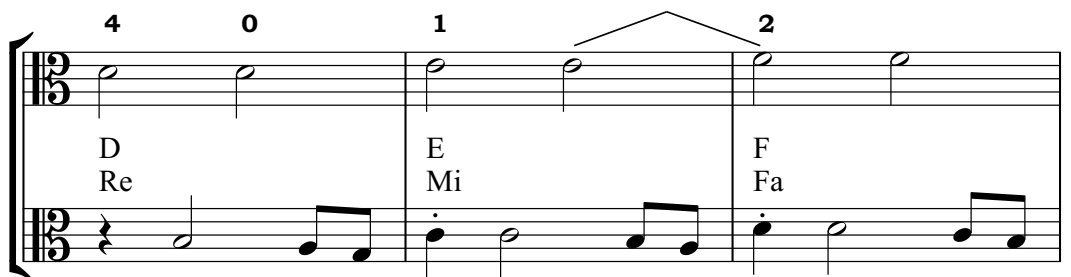
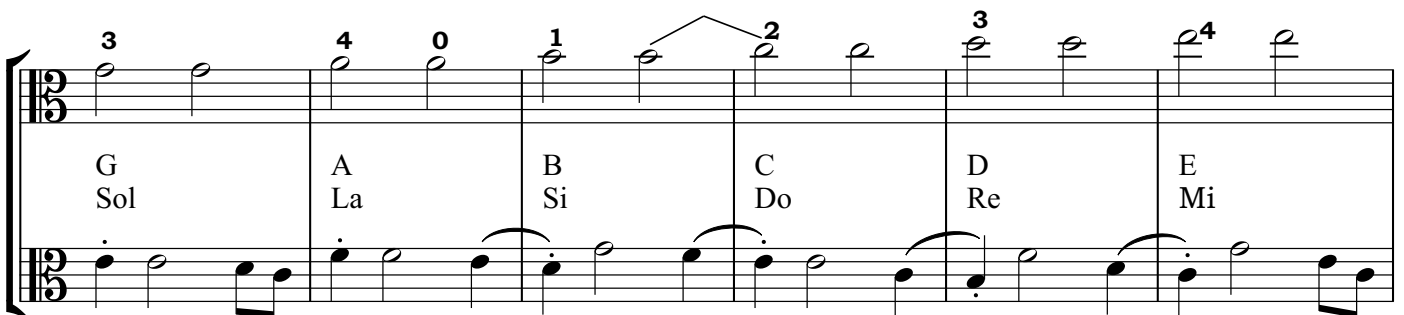
The first system of musical notation consists of two staves. The top staff is a treble clef with a 3/4 time signature. It contains six measures of music, each with a chord name and a solfège syllable: D Re, C Do, B Si, A La, G Sol, and F Fa. The bottom staff is a bass clef with a 3/4 time signature, containing six measures of music corresponding to the chords above. Fingering numbers (3, 2, 1, 0, 4, 3, 2) are placed above the notes in the top staff. The notes in the bottom staff are mostly quarter notes with some eighth notes and rests.

The second system of musical notation consists of two staves. The top staff is a treble clef with a 3/4 time signature. It contains five measures of music, each with a chord name and a solfège syllable: E Mi, D Re, C Do, B Si, and A La. The bottom staff is a bass clef with a 3/4 time signature, containing five measures of music corresponding to the chords above. Fingering numbers (1, 0, 4, 3, 2, 1) are placed above the notes in the top staff. The notes in the bottom staff are mostly quarter notes with some eighth notes and rests.

The third system of musical notation consists of two staves. The top staff is a treble clef with a 3/4 time signature. It contains five measures of music, each with a chord name and a solfège syllable: G Sol, F Fa, E Mi, D Re, and C Do. The bottom staff is a bass clef with a 3/4 time signature, containing five measures of music corresponding to the chords above. Fingering numbers (0, 4, 3, 2, 1, 0) are placed above the notes in the top staff. The notes in the bottom staff are mostly quarter notes with some eighth notes and rests.

A MINOR

melodic up

C G D A

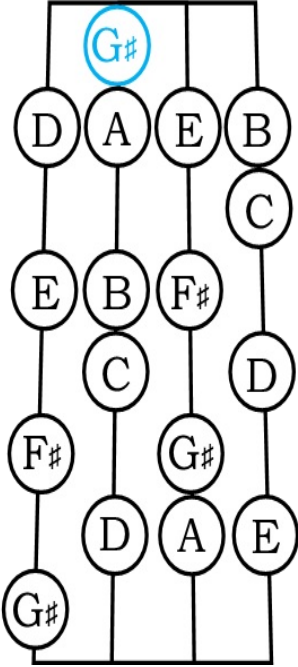

A MINOR

melodic down

C G D A

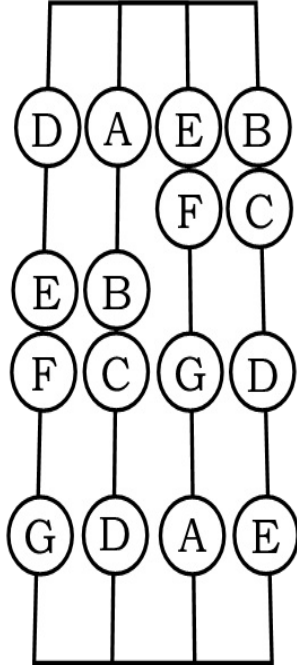

Musical notation for the first measure of the A minor scale. The treble clef has a whole note 'A' (labeled 'A La'). The bass clef has a half note 'G#' followed by a half note 'A'. A first finger fingering '1' is indicated above the treble clef.

Musical notation for the second measure of the A minor scale. The treble clef has a whole note 'B' (labeled 'B Si') and a whole note 'C' (labeled 'C Do'). The bass clef has a half note 'B' followed by a half note 'C'. A second finger fingering '2' is indicated above the treble clef, and a third finger fingering '3' is indicated above the treble clef.

Musical notation for the third measure of the A minor scale. The treble clef has a whole note 'D' (labeled 'D Re') and a whole note 'E' (labeled 'E Mi'). The bass clef has a half note 'D' followed by a half note 'E'. A fourth finger fingering '4' is indicated above the treble clef, and a first finger fingering '1' is indicated above the treble clef.

Musical notation for the fourth measure of the A minor scale. The treble clef has a whole note 'F#' (labeled 'F# Fa#') and a whole note 'G#' (labeled 'G# Sol#'). The bass clef has a half note 'F#' followed by a half note 'G#'. A second finger fingering '2' is indicated above the treble clef, and a third finger fingering '3' is indicated above the treble clef.

Musical notation for the fifth measure of the A minor scale. The treble clef has a whole note 'C' (labeled 'C Do') and a whole note 'D' (labeled 'D Re'). The bass clef has a half note 'C' followed by a half note 'D'. A second finger fingering '2' is indicated above the treble clef, and a third finger fingering '3' is indicated above the treble clef.

Musical notation for the sixth measure of the A minor scale. The treble clef has a whole note 'C' (labeled 'C Do'), a whole note 'B' (labeled 'B Si'), a whole note 'A' (labeled 'A La'), and a whole note 'G#' (labeled 'G# Sol#'). The bass clef has a half note 'C' followed by a half note 'B', a half note 'A', and a half note 'G#'. A second finger fingering '2' is indicated above the treble clef, and a first finger fingering '1' is indicated above the treble clef.

2 1 0 4

F#
Fa#

E
Mi

D
Re

3 2 1

C
Do

B
Si

A
La

G MAJOR

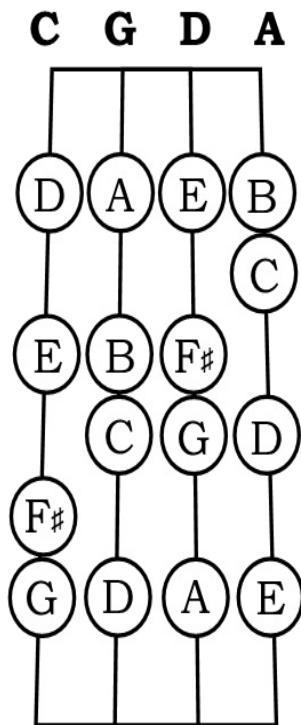

0 1 2 3

G
Sol

A
La

B
Si

C
Do

4 0 1 2 3

D
Re

E
Mi

F#
Fa#

G
Sol

4 0 1 2 3

A
La

B
Si

C
Do

D
Re

4 3 2 1 0 4 3

E Mi D Re C Do B Si A La G Sol

This system contains six measures of music. The top staff shows a melodic line with fingerings 4, 3, 2, 1, 0, 4, 3. The notes are E, D, C, B, A, G. Below the staff, the notes are labeled with their solfège names: E Mi, D Re, C Do, B Si, A La, G Sol. The bottom staff shows a bass line accompaniment.

2 1 0 4

F# Fa# E Mi D Re

This system contains three measures of music. The top staff shows a melodic line with fingerings 2, 1, 0, 4. The notes are F#, E, D. Below the staff, the notes are labeled with their solfège names: F# Fa#, E Mi, D Re. The bottom staff shows a bass line accompaniment.

3 2 1 0

C Do B Si A La G Sol

This system contains four measures of music. The top staff shows a melodic line with fingerings 3, 2, 1, 0. The notes are C, B, A, G. Below the staff, the notes are labeled with their solfège names: C Do, B Si, A La, G Sol. The bottom staff shows a bass line accompaniment.

E MINOR

melodic up

C G D A

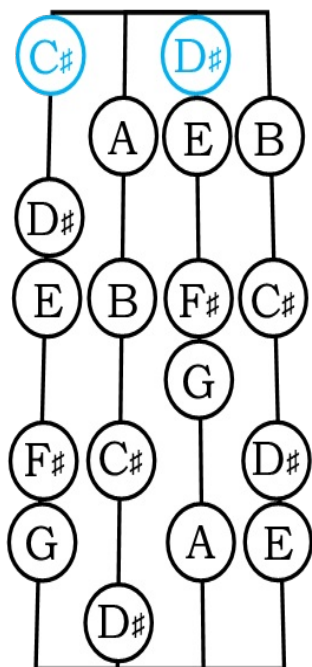

E MINOR

melodic down

C G D A

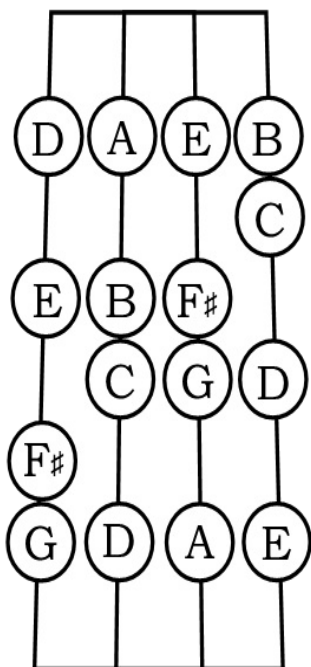

3 2 1 0 4

D \sharp Re \sharp C \sharp Do \sharp B Si A La

This system contains the first four measures of the piece. The treble clef staff shows a sequence of notes: D \sharp (finger 3), E \sharp (finger 2), F \sharp (finger 1), G (finger 0), A (finger 4), B (finger 1), C \sharp (finger 2), D \sharp (finger 3). The bass clef staff provides accompaniment with chords and moving lines. The notes D \sharp , C \sharp , B, and A are explicitly labeled with their solfège equivalents: Re \sharp , Do \sharp , Si, and La.

3 2 1 0 4

G Sol F \sharp Fa \sharp E Mi D Re

This system contains measures 5 through 8. The treble clef staff continues the sequence: G (finger 3), A (finger 2), B (finger 1), C (finger 0), D (finger 4), E (finger 1), F \sharp (finger 2), G \sharp (finger 3). The bass clef staff continues the accompaniment. The notes G, F \sharp , E, and D are explicitly labeled with their solfège equivalents: Sol, Fa \sharp , Mi, and Re.

3 2 1

C Do B Si A La

This system contains measures 9 through 11. The treble clef staff continues the sequence: G \sharp (finger 3), A (finger 2), B (finger 1), C (finger 0), D (finger 1), E (finger 2), F \sharp (finger 1), G \sharp (finger 2). The bass clef staff continues the accompaniment. The notes C, B, and A are explicitly labeled with their solfège equivalents: Do, Si, and La.

0 4 3 2

G Sol F \sharp Fa \sharp E Mi

This system contains the final three measures of the piece. The treble clef staff continues the sequence: G (finger 0), A (finger 4), B (finger 3), C (finger 2), D (finger 1), E (finger 2), F \sharp (finger 3), G \sharp (finger 4). The bass clef staff continues the accompaniment. The notes G, F \sharp , and E are explicitly labeled with their solfège equivalents: Sol, Fa \sharp , and Mi.

D MAJOR

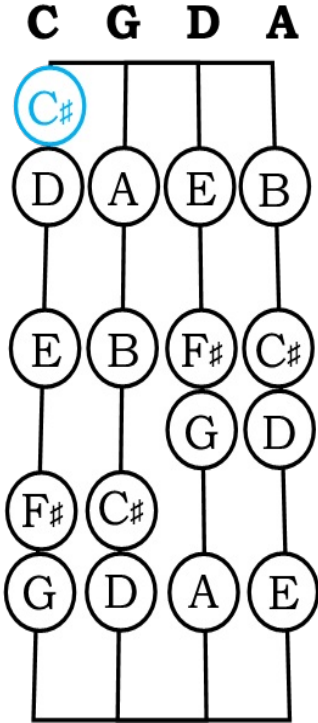

1 2 3

D Re E Mi F# Fa#

4 0 1 2

G Sol A La B Si

3 4 0 1

C# Do# D Re E Mi

2 3 4 0 1

F# Fa# G Sol A La B Si

2 3 4 3

C# Do# D Re E Mi D Re

2 1 0 4 3

C#
Do#

B
Si

A
La

G
Sol

This system contains the first four measures of the piece. The top staff shows a melodic line with fingerings 2, 1, 0, 4, and 3. The bottom staff shows a bass line with a trill in the first measure. The notes are C# (Do#), B (Si), A (La), and G (Sol).

2 1 0 4 3

F#
Fa#

E
Mi

D
Re

C#
Do#

This system contains measures 5 through 8. The top staff continues the melodic line with fingerings 2, 1, 0, 4, and 3. The bottom staff continues the bass line. The notes are F# (Fa#), E (Mi), D (Re), and C# (Do#).

2 1 0 4

B
Si

A
La

G
Sol

This system contains measures 9 through 12. The top staff continues the melodic line with fingerings 2, 1, 0, and 4. The bottom staff continues the bass line. The notes are B (Si), A (La), and G (Sol).

3 2 1

F#
Fa#

E
Mi

D
Re

This system contains the final three measures of the piece. The top staff continues the melodic line with fingerings 3, 2, and 1. The bottom staff continues the bass line. The notes are F# (Fa#), E (Mi), and D (Re).

B MINOR

melodic up

C G D A

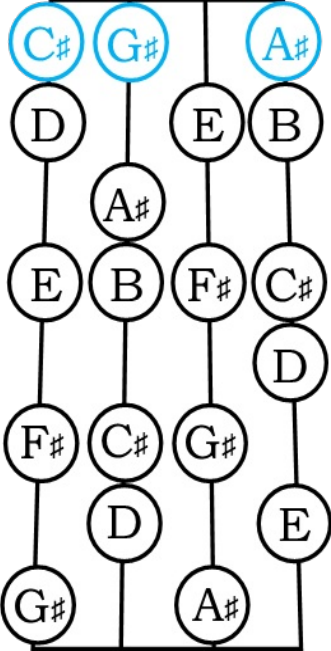

B MINOR

melodic down

C G D A

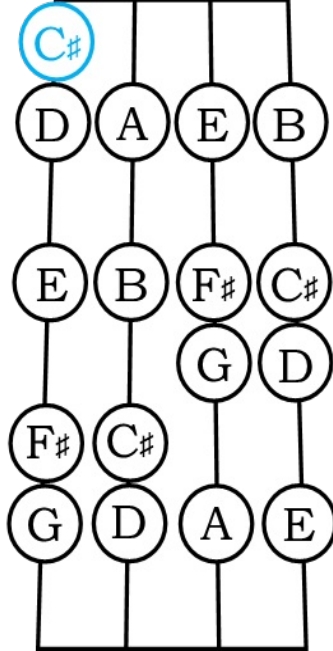

Musical notation for the B minor melodic up scale, measure 2. The treble clef has a whole note B (Si). The bass clef has a quarter rest followed by eighth notes C# (Do#), D, E, and B.

Musical notation for the B minor melodic up scale, measure 3. The treble clef has a whole note C# (Do#). The bass clef has a quarter rest followed by eighth notes D, E, B, and C#.

Musical notation for the B minor melodic up scale, measures 4 and 5. Measure 4: Treble clef has a whole note D (Re). Bass clef has a quarter rest followed by eighth notes E, B, C#, and D. Measure 5: Treble clef has a whole note E (Mi). Bass clef has a quarter rest followed by eighth notes A, G, D, and E.

Musical notation for the B minor melodic down scale, measures 2-5. Measure 2: Treble clef has a whole note F# (Fa#). Bass clef has a quarter rest followed by eighth notes E, D, C#, and B. Measure 3: Treble clef has a whole note G# (Sol#). Bass clef has a quarter rest followed by eighth notes F#, E, D, and C#. Measure 4: Treble clef has a whole note A# (La#). Bass clef has a quarter rest followed by eighth notes G#, F#, E, and D. Measure 5: Treble clef has a whole note B (Si). Bass clef has a quarter rest followed by eighth notes A, G, F#, and E.

Musical notation for the B minor melodic down scale, measures 6-9. Measure 6: Treble clef has a whole note C# (Do#). Bass clef has a quarter rest followed by eighth notes B, A, G, and F#. Measure 7: Treble clef has a whole note D (Re). Bass clef has a quarter rest followed by eighth notes C#, B, A, and G. Measure 8: Treble clef has a whole note E (Mi). Bass clef has a quarter rest followed by eighth notes D, C#, B, and A. Measure 9: Treble clef has a whole note D (Re). Bass clef has a quarter rest followed by eighth notes C#, B, A, and G.

Musical notation for the B minor melodic down scale, measures 10-13. Measure 10: Treble clef has a whole note C# (Do#). Bass clef has a quarter rest followed by eighth notes B, A, G, and F#. Measure 11: Treble clef has a whole note B (Si). Bass clef has a quarter rest followed by eighth notes A, G, F#, and E. Measure 12: Treble clef has a whole note A# (La#). Bass clef has a quarter rest followed by eighth notes G#, F#, E, and D. Measure 13: Treble clef has a whole note G# (Sol#). Bass clef has a quarter rest followed by eighth notes F#, E, D, and C#.

F# Fa# E Mi D Re C# Do# B Si

A MAJOR

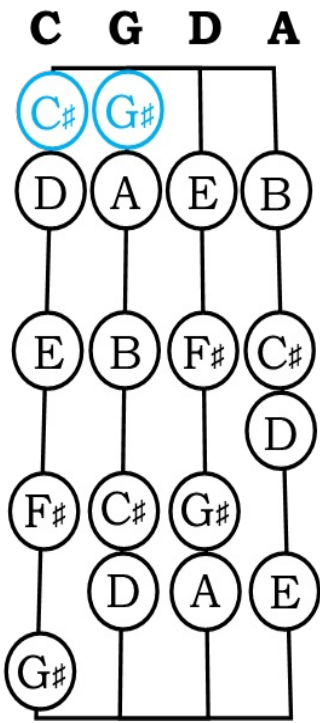

A La B Si C# Do# D Re

E Mi F# Fa# G# Sol# A La

B Si C# Do# D Re E Mi

D Re C# Do# B Si A La G# Sol#

F# Fa# E Mi D Re C# Do# B Si# A La

F# MINOR

melodic up

C G D A

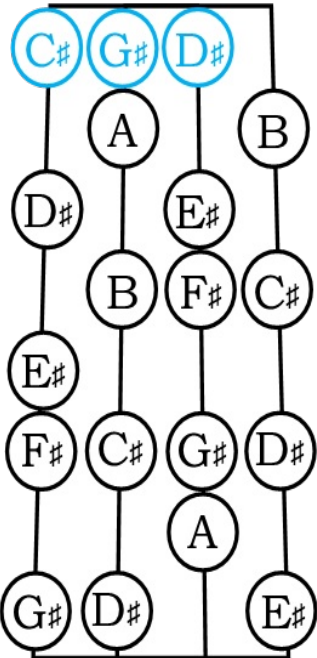

F# MINOR

melodic down

C G D A

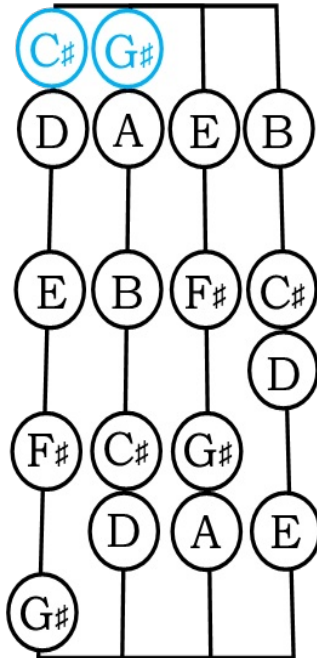

Musical notation for the first two measures of the F# minor melodic up scale. The key signature has three sharps (F#, C#, G#). The first measure contains notes F# and Fa# with a fingering of 3 and a breath mark. The second measure contains notes G# and Sol# with a fingering of 4.

Musical notation for the third and fourth measures of the F# minor melodic up scale. The third measure contains notes A and La with a fingering of 1 and a breath mark. The fourth measure contains notes B and Si with a fingering of 2.

Musical notation for the fifth and sixth measures of the F# minor melodic up scale. The fifth measure contains notes C# and Do# with a fingering of 3. The sixth measure contains notes D# and Re# with a fingering of 4.

Musical notation for the first five measures of the F# minor melodic down scale. The notes and fingerings are: E# (Mi#) with fingering 1, F# (Fa#) with fingering 2, G# (Sol#) with fingering 3, A (La) with fingering 4, and B (Si) with fingering 0.

Musical notation for the next five measures of the F# minor melodic down scale. The notes and fingerings are: C# (Do#) with fingering 2, D (Re) with fingering 3, C# (Do#) with fingering 2, B (Si) with fingering 1, and A (La) with fingering 0.

Musical notation for the final four measures of the F# minor melodic down scale. The notes and fingerings are: G# (Sol#) with fingering 3, F# (Fa#) with fingering 2, E# (Mi#) with fingering 1, and D# (Re#) with fingering 0.

3 2 1 4 3

C# Do# B Si# A La G# Sol# F# Fa#

E MAJOR

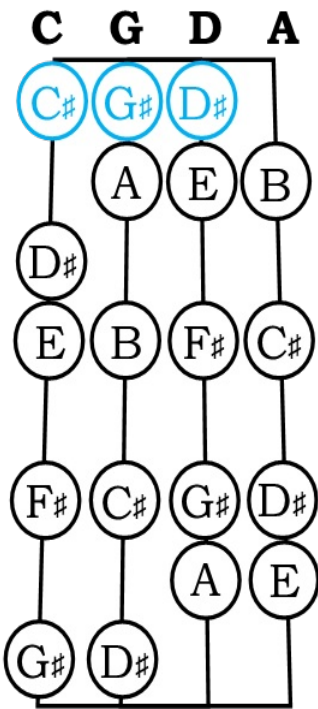

E Mi F# Fa# G# Sol#

A La B Si C# Do#

D# Re# E Mi F# Fa#

G# Sol# A La B Si C# Do# D# Re#

First system of musical notation. The treble staff contains a series of eighth-note chords: E4, D#4, C#4, B3, A3. The bass staff contains a series of eighth-note chords: E3, D#3, C#3, B2, A2. The notes are labeled with their letter names and solfège equivalents: E Mi, D# Re#, C# Do#, B Si, A La.

Second system of musical notation. The treble staff contains a series of eighth-note chords: G#4, F#4, E4, D#4, C#4. The bass staff contains a series of eighth-note chords: G#3, F#3, E3, D#3, C#3. The notes are labeled with their letter names and solfège equivalents: G# Sol#, F# Fa#, E Mi, D# Re#, C# Do#.

Third system of musical notation. The treble staff contains a series of eighth-note chords: B4, A4, G#4, F#4, E4. The bass staff contains a series of eighth-note chords: B3, A3, G#3, F#3, E3. The notes are labeled with their letter names and solfège equivalents: B Si, A La, G# Sol#, F# Fa#, E Mi.

C# MINOR

melodic up

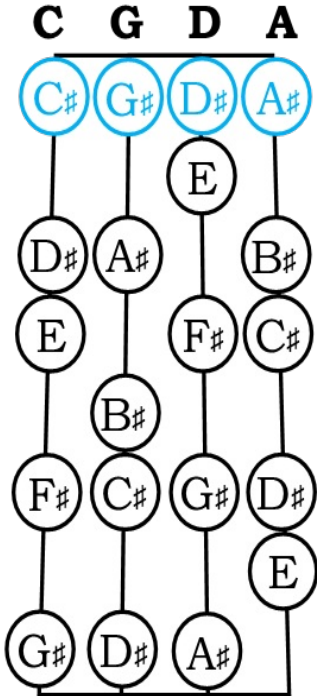

C# MINOR

melodic down

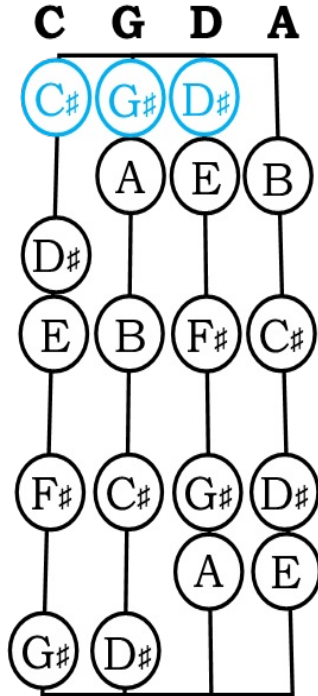

Musical notation for the C# minor melodic up scale. It features a treble clef, a key signature of three sharps (F#, C#, G#), and a 4/4 time signature. The melody starts on C# (Do#) and ascends through D# (Re#), E (Mi), F# (Fa#), G# (Sol#), and A (La#). The bass line provides accompaniment with chords and moving lines.

Musical notation for the C# minor melodic down scale. It features a treble clef, a key signature of three sharps (F#, C#, G#), and a 4/4 time signature. The melody starts on A (La#) and descends through G# (Sol#), F# (Fa#), E (Mi), D# (Re#), and C# (Do#). The bass line provides accompaniment with chords and moving lines.

Musical notation for the C# minor melodic up scale. It features a treble clef, a key signature of three sharps (F#, C#, G#), and a 4/4 time signature. The melody starts on G# (Sol#) and ascends through A (La#). The bass line provides accompaniment with chords and moving lines.

Musical notation for the C# minor melodic down scale. It features a treble clef, a key signature of three sharps (F#, C#, G#), and a 4/4 time signature. The melody starts on E (Mi) and descends through D# (Re#), C# (Do#), and B# (Si#). The bass line provides accompaniment with chords and moving lines.

Musical notation for the C# minor melodic up scale. It features a treble clef, a key signature of three sharps (F#, C#, G#), and a 4/4 time signature. The melody starts on F# (Fa#) and ascends through G# (Sol#), A (La#), and B (Si#). The bass line provides accompaniment with chords and moving lines.

First system of musical notation, measures 1-4. The key signature is three sharps (F#, C#, G#) and the time signature is 3/8. The notation includes a treble clef with a soprano line and a bass clef with an alto line. The soprano line features a melodic line with a slur and a fermata over the final note. The alto line features a bass line with a slur and a fermata over the final note. Chord labels are provided for each measure: C# Do# (measures 1-2), Bb Do# (measures 3-4), Ab La# (measures 1-2), and G# Sol# (measures 3-4).

Second system of musical notation, measures 5-8. The key signature is three sharps (F#, C#, G#) and the time signature is 3/8. The notation includes a treble clef with a soprano line and a bass clef with an alto line. The soprano line features a melodic line with a slur and a fermata over the final note. The alto line features a bass line with a slur and a fermata over the final note. Chord labels are provided for each measure: F# Fa# (measures 5-6), E Mi (measures 7-8), D# Re# (measures 5-6), and C# Do# (measures 7-8).

Third system of musical notation, measures 9-11. The key signature is three sharps (F#, C#, G#) and the time signature is 3/8. The notation includes a treble clef with a soprano line and a bass clef with an alto line. The soprano line features a melodic line with a slur and a fermata over the final note. The alto line features a bass line with a slur and a fermata over the final note. Chord labels are provided for each measure: Bb Sib (measures 9-10), Ab La# (measures 10-11), and G# Sol# (measures 9-11).

Fourth system of musical notation, measures 12-15. The key signature is three sharps (F#, C#, G#) and the time signature is 3/8. The notation includes a treble clef with a soprano line and a bass clef with an alto line. The soprano line features a melodic line with a slur and a fermata over the final note. The alto line features a bass line with a slur and a fermata over the final note. Chord labels are provided for each measure: F# Fa# (measures 12-13), E Mi (measures 14-15), D# Re# (measures 12-13), and C# Do# (measures 14-15).

F MAJOR

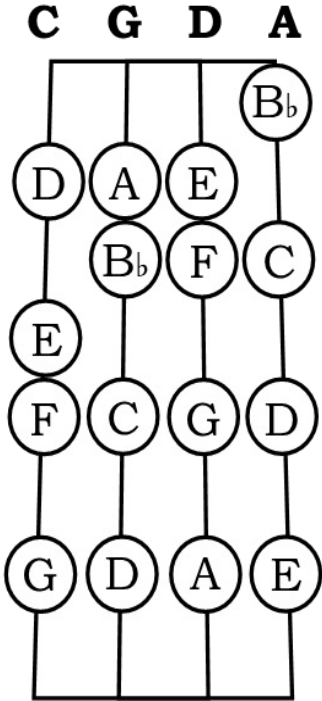

First system of musical notation for F Major. It consists of two staves (treble and bass clef) in 3/4 time. The treble staff has a key signature of one flat (Bb) and a common time signature (C). The notes are: F (Fas) on the first beat, G (Sol) on the second beat, A (La) on the third beat, and Bb (Sib) on the fourth beat. The bass staff provides a rhythmic accompaniment with eighth and quarter notes.

Second system of musical notation for F Major. It consists of two staves. The treble staff notes are: C (Do) on the first beat, D (Re) on the second beat, E (Mi) on the third beat, and F (Fa) on the fourth beat. The bass staff continues the accompaniment.

Third system of musical notation for F Major. It consists of two staves. The treble staff notes are: G (Sol) on the first beat, A (La) on the second beat, Bb (Sib) on the third beat, C (Do) on the fourth beat, and D (Re) on the fifth beat. The bass staff continues the accompaniment.

Fourth system of musical notation for F Major. It consists of two staves. The treble staff notes are: E (Mi) on the first beat, D (Re) on the second beat, C (Do) on the third beat, Bb (Sib) on the fourth beat, A (La) on the fifth beat, G (Sol) on the sixth beat, and F (Fa) on the seventh beat. The bass staff continues the accompaniment.

Fifth system of musical notation for F Major. It consists of two staves. The treble staff notes are: E (Mi) on the first beat, D (Re) on the second beat, C (Do) on the third beat, Bb (Sib) on the fourth beat, A (La) on the fifth beat, G (Sol) on the sixth beat, and F (Fa) on the seventh beat. The bass staff continues the accompaniment.

D MINOR

melodic up

C G D A

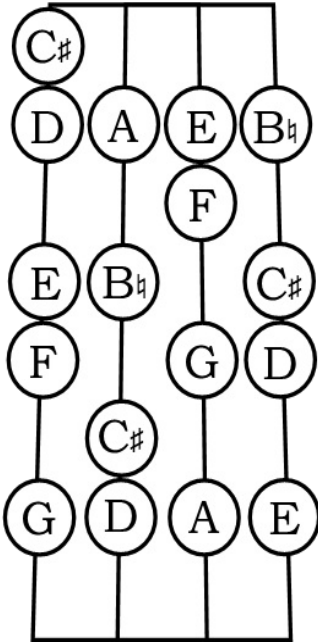

D MINOR

melodic down

C G D A

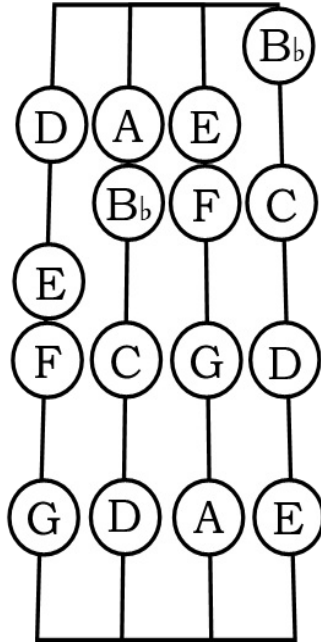

1 4 0 3 2 1 0 4

Bb Sib A La G Sol F Fa E Mi D Re

3 2 1

C Do Bb Sib A La

0 4 3 2 1

G Sol F Fa E Mi D Re

B \flat MAJOR

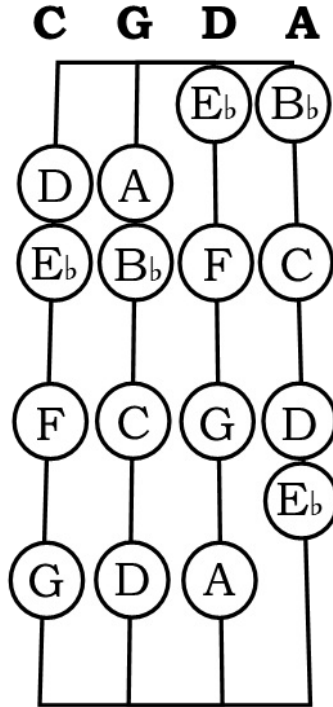

2 3 4 1 2 3

B \flat C D Eb F G
Sib Do Re Mib Fa Sol

4 1 2 3 4 3

A B \flat C D Eb D
La Sib Do Re Mib Re

2 1 4 3 2 1 4 3 2

C B \flat A G F Eb D C B \flat
Do Sib La Sol Fa Mib Re Do Cib

G MINOR

melodic up

C G D A

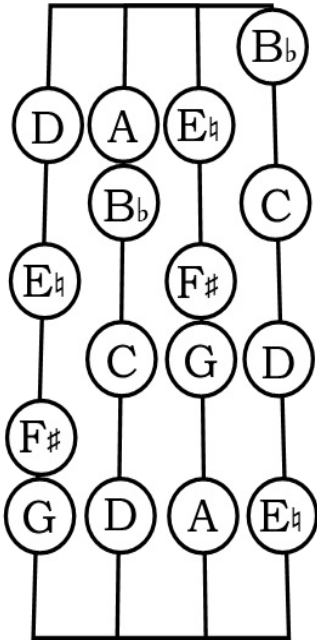

G MINOR

melodic down

C G D A

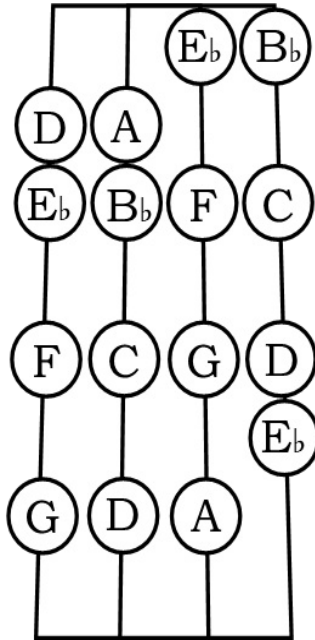

Musical notation for the first system of the G minor scale, measures 1-3. The top staff shows the melody with notes G (Sol) and A (La). The bottom staff shows the accompaniment. Measure 1: G (Sol) in the melody, G (Sol) in the accompaniment. Measure 2: A (La) in the melody, A (La) in the accompaniment. Measure 3: A (La) in the melody, A (La) in the accompaniment.

Musical notation for the second system of the G minor scale, measures 4-7. The top staff shows the melody with notes F# (Fa#), G (Sol), A (La), Bb (Sib), C (Do), D (Re), Eb (Mib), and D (Re). The bottom staff shows the accompaniment. Measure 4: F# (Fa#) in the melody, F# (Fa#) in the accompaniment. Measure 5: G (Sol) in the melody, G (Sol) in the accompaniment. Measure 6: A (La) in the melody, A (La) in the accompaniment. Measure 7: Bb (Sib) in the melody, Bb (Sib) in the accompaniment.

Musical notation for the third system of the G minor scale, measures 8-11. The top staff shows the melody with notes C (Do), Bb (Sib), A (La), G (Sol), F (Fa), and Eb (Mib). The bottom staff shows the accompaniment. Measure 8: C (Do) in the melody, C (Do) in the accompaniment. Measure 9: Bb (Sib) in the melody, Bb (Sib) in the accompaniment. Measure 10: A (La) in the melody, A (La) in the accompaniment. Measure 11: G (Sol) in the melody, G (Sol) in the accompaniment.

Musical notation for the fourth system of the G minor scale, measures 12-14. The top staff shows the melody with notes D (Re), C (Do), Bb (Sib), A (La), and G (Sol). The bottom staff shows the accompaniment. Measure 12: D (Re) in the melody, D (Re) in the accompaniment. Measure 13: C (Do) in the melody, C (Do) in the accompaniment. Measure 14: Bb (Sib) in the melody, Bb (Sib) in the accompaniment.

E_b MAJOR

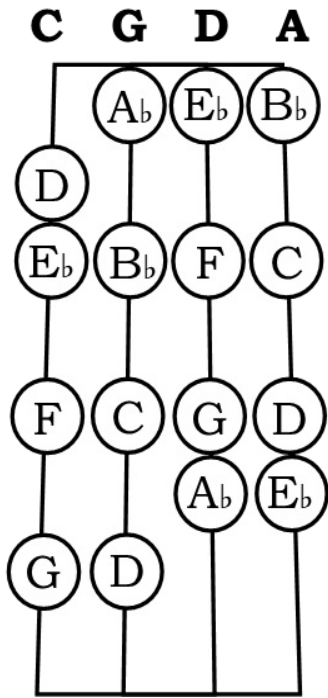

Musical score for Eb Major in 3/4 time, featuring a vocal line and a piano accompaniment.

Vocal Line:

2 3 4 1 2 3 4 1 2 3 4 1

E_b F G A_b B_b C D E_b F G A_b B_b
 Mi_b Fa Sol La_b Si_b Do Re Mi_b Fa Sol La_b Si_b

Piano Accompaniment:

C D E_b D C B_b A_b G
 Do Re Mi_b Re Do Si_b La_b Sol

F E_b D C B_b A_b G F E_b
 Fa Mi_b Re Do Si_b La_b Sol Fa Mi_b

C MINOR

melodic up

C G D A

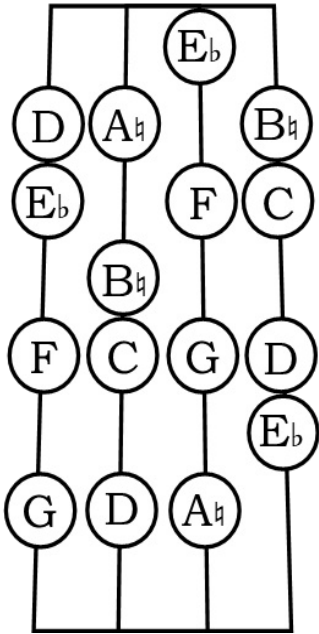

C MINOR

melodic down

C G D A

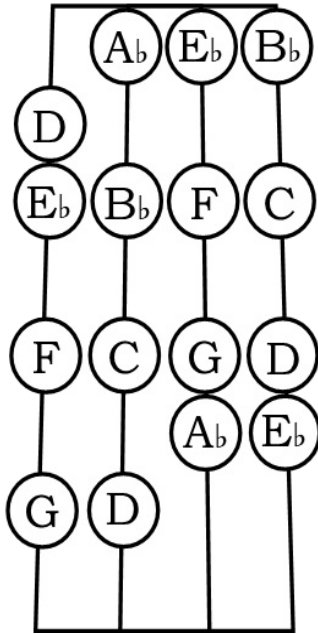

A_b MAJOR

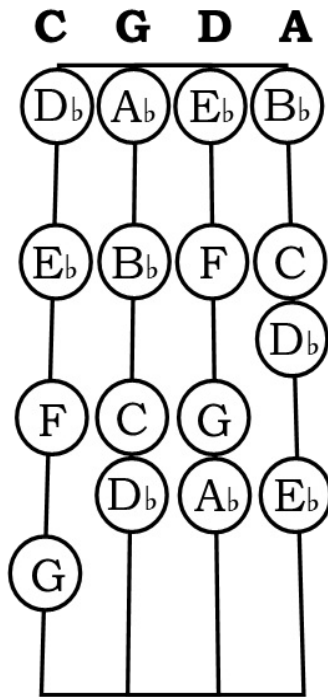

1 2 3 4

1 2 3 4

1. 2. 3. 4.

3. 2. 1. 4. 3.

2 1 4

3 2 1

F MINOR

melodic up

C G D A

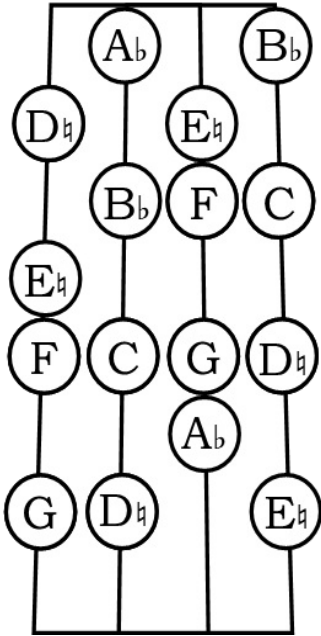

F MINOR

melodic down

C G D A

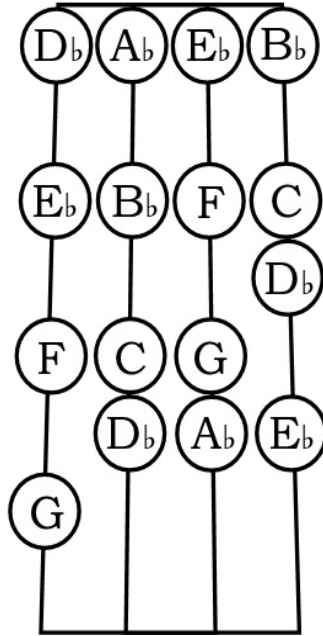

3 2 1 4

G Sol F Fa Eb Mi♭ D♭ Re♭

This system contains the first four measures of a piece. The top staff is in treble clef with a key signature of two flats (Bb, Eb) and a 3/4 time signature. It features a melodic line with a triplet of eighth notes in the first measure, followed by quarter notes. The bottom staff is in bass clef and provides a harmonic accompaniment with eighth and quarter notes. Chord symbols are placed below the first staff: G (Sol) in measure 1, F (Fa) in measure 2, Eb (Mi♭) in measure 3, and D♭ (Re♭) in measure 4. Fingerings 3, 2, 1, and 4 are indicated above the notes in the top staff.

3 2 1 0 4 3

C Do B♭ Sib A♭ Lab G Sol F Fa

This system contains the next four measures. The notation continues from the first system. The top staff has a triplet of eighth notes in measure 5, followed by quarter notes. The bottom staff continues the accompaniment. Chord symbols are: C (Do) in measure 5, B♭ (Sib) in measure 6, A♭ (Lab) in measure 7, G (Sol) in measure 8, and F (Fa) in measure 9. Fingerings 3, 2, 1, 0, 4, and 3 are indicated above the notes in the top staff.